

C-Series

CENTRIFUGAL PUMP - NEMA VERSION

FORM NO.: 95-03008-NEMA REVISION: 10/2012

READ AND UNDERSTAND THIS MANUAL PRIOR TO OPERATING OR SERVICING THIS PRODUCT.

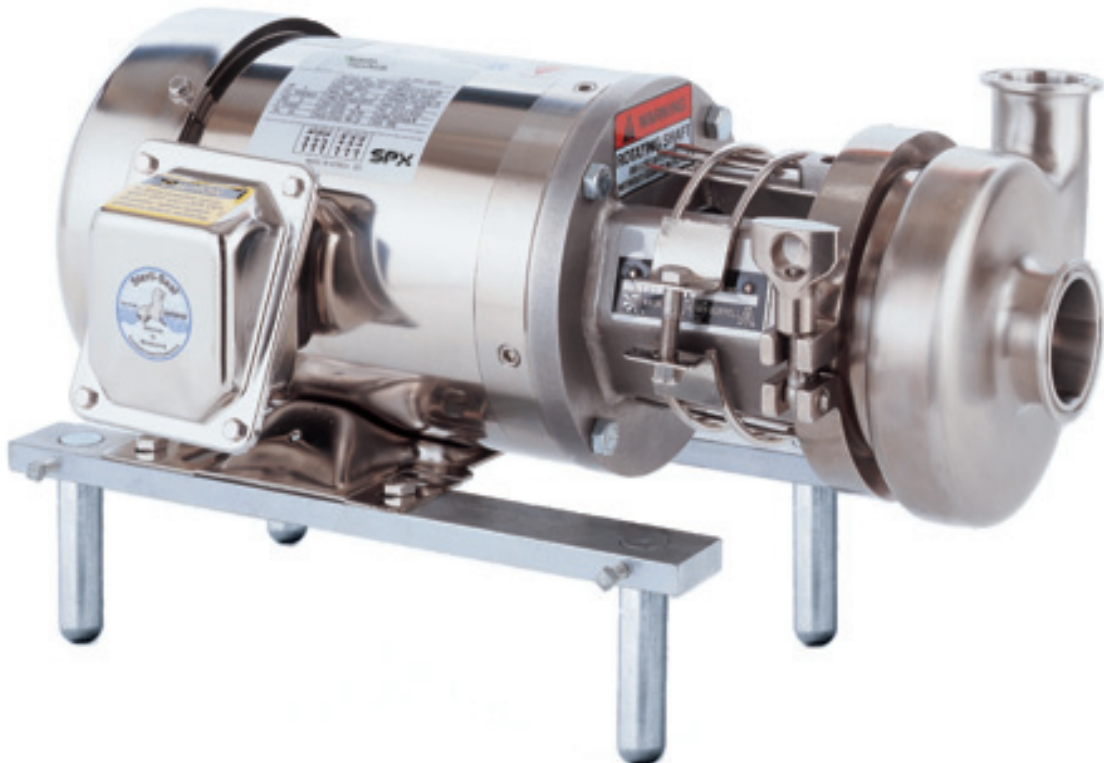



SPX Flow Technology
611 Sugar Creek Road
Delavan, WI 53115 USA

Tel: (800) 252-5200 or (262) 728-1900
Fax: (800) 252-5012 or (262) 728-4904

E-mail: wcb@spx.com
Web site: www.spx.com

Information contained in this manual is subject to change without notice and does not represent a commitment on the part of SPX Corporation. No part of this manual may be reproduced or transmitted in any form or by any means, electronic or mechanical, including photocopying and recording, for any purpose, without the express written permission of SPX Corporation.

Copyright © 2012 SPX Corporation

All Rights Reserved

Revision Date: 10/2012

Publication: 95-03008-NEMA

Warranty	2
Shipping Damage or Loss	2
Warranty Claim	2
Safety	3
Care of Stainless Steel	4
Stainless Steel Corrosion	4
Elastomer Seal Replacement Following Passivation	4
Introduction	5
Operating Parameters	6
Pump Dimensions	6
Installation	9
Pump Location	9
Pump Leveling	9
Supply and Discharge Piping/Valves	9
Installations That May Cause Operation Problems	11
Electrical Connections	11
Flush Seal Option	11
Before First Startup	12
Cleaning Safety Procedures	12
Operation	13
Starting the Pump	13
Priming the Pump	13
Stopping the Pump	14
Maintenance	15
Scheduled Maintenance	15
Pump Disassembly	15
Replacing the Motor	17
Installing the Adapter	17
Stub Shaft Adjustment	18
Parts Lists	24
C-100 Pump Parts	24
C-114 Pump Parts	26
C-216 Pump Parts	28
C-218 Pump Parts	30
C-328 Pump Parts	32
Type "DG" Seal Assembly Option	34
Type "E" Water-Cooled Balanced Double Seal Option	35
C-Series Kit Parts	36
Motor Mounts - NEMA Frame Sizes	38
Troubleshooting	39

Warranty

Seller warrants its products to be free from defect in materials and workmanship for a period of one (1) year from the date of shipment. This warranty shall not apply to products which require repair or replacement due to normal wear and tear or to products which are subjected to accident, misuse or improper maintenance. This warranty extends only to the original Buyer. Products manufactured by others but furnished by Seller are exempted from this warranty and are limited to the original manufacturer's warranty.

Seller's sole obligation under this warranty shall be to repair or replace any products that Seller determines, in its discretion, to be defective. Seller reserves the right either to inspect the products in the field or to request their prepaid return to Seller. Seller shall not be responsible for any transportation charges, duty, taxes, freight, labor or other costs. The cost of removing and/or installing products which have been repaired or replaced shall be at Buyer's expense.

Seller expressly disclaims all other warranties, express or implied, including without limitation any warranty of merchantability of fitness for a particular purpose. The foregoing sets forth Seller's entire and exclusive liability, and Buyer's exclusive and sole remedy, for any claim of damages in connection with the sale of products. In no event shall Seller be liable for any special consequential incidental or indirect damages (including without limitation attorney's fees and expenses), nor shall Seller be liable for any loss of profit or material arising out of or relating to the sale or operation of the products based on contract, tort (including negligence), strict liability or otherwise.

Shipping Damage or Loss

If equipment is damaged or lost in transit, file a claim at once with the delivering carrier. The carrier has signed the Bill of Lading acknowledging that the shipment has been received from SPX Flow Technology in good condition. SPX Flow Technology is not responsible for the collection of claims or replacement of materials due to transit shortages or damages.

Warranty Claim

Warranty claims must have a **Returned Goods Authorization (RGA)** from the Seller before returns will be accepted.

Claims for shortages or other errors, exclusive of transit shortages or damages, must be made in writing to Seller within ten (10) days after delivery. Failure to give such notice shall constitute acceptance and waiver of all such claims by Buyer.

Safety

READ AND UNDERSTAND THIS MANUAL PRIOR TO INSTALLING, OPERATING OR SERVICING THIS EQUIPMENT

SPX recommends users of our equipment and designs follow the latest Industrial Safety Standards. At a minimum, these should include the industrial safety requirements established by:

1. Occupational Safety and Health Administration (OSHA), Title 29 of the CFR
Section 1910.212- General Requirements for all Machines
2. National Fire Protection Association, ANSI/NFPA 79
ANSI/NFPA 79- Electrical Standards for Industrial Machinery
3. National Electrical Code, ANSI/NFPA 70
ANSI/NFPA 70- National Electrical Code
ANSI/NFPA 70E- Electrical Safety Requirement for Employee Workplaces
4. American National Standards Institute, Section B11

Attention: Servicing energized industrial equipment can be hazardous. Severe injury or death can result from electrical shock, burn, or unintended actuation of controlled equipment. Recommended practice is to disconnect and lockout industrial equipment from power sources, and release stored energy, if present. Refer to the National Fire Protection Association Standard No. NFPA70E, Part II and (as applicable) OSHA rules for Control of Hazardous Energy Sources (Lockout-Tagout) and OSHA Electrical Safety Related Work Practices, including procedural requirements for:

- Lockout-tagout
- Personnel qualifications and training requirements
- When it is not feasible to de-energize and lockout-tagout electrical circuits and equipment before working on or near exposed circuit parts

Locking and Interlocking Devices: These devices should be checked for proper working condition and capability of performing their intended functions. Make replacements only with the original manufacturer's renewal parts or kits. Adjust or repair in accordance with the manufacturer's instructions.

Periodic Inspection: Industrial equipment should be inspected periodically. Inspection intervals should be based on environmental and operating conditions and adjusted as indicated by experience. At a minimum, an initial inspection within 3 to 4 months after installation is recommended. Inspection of the electrical control systems should meet the recommendations as specified in the National Electrical Manufacturers Association (NEMA) Standard No. ICS 1.3, Preventative Maintenance of Industrial Control and Systems Equipment, for the general guidelines for setting-up a periodic maintenance program.

Replacement Equipment: Use only replacement parts and devices recommended by the manufacturer to maintain the integrity of the equipment. Make sure the parts are properly matched to the equipment series, model, serial number, and revision level of the equipment.

Warnings and cautions are provided in this manual to help avoid serious injury and/or possible damage to equipment:



DANGER: marked with a stop sign.
Immediate hazards which WILL result in severe personal injury or death.



WARNING: marked with a warning triangle.
Hazards or unsafe practices which COULD result in severe personal injury or death.



CAUTION: marked with a warning triangle.
Hazards or unsafe practices which COULD result in minor personal injury or product or property damage.

Care of Stainless Steel

Stainless Steel Corrosion

Corrosion resistance is greatest when a layer of oxide film is formed on the surface of stainless steel. If film is disturbed or destroyed, stainless steel becomes much less resistant to corrosion and may rust, pit or crack.

Corrosion pitting, rusting and stress cracks may occur due to chemical attack. Use only cleaning chemicals specified by a reputable chemical manufacturer for use with 300 series stainless steel. Do not use excessive concentrations, temperatures or exposure times. Avoid contact with highly corrosive acids such as hydrofluoric, hydrochloric or sulfuric. Also avoid prolonged contact with chloride-containing chemicals, especially in presence of acid. If chlorine-based sanitizers are used, such as sodium hypochlorite (bleach), do not exceed concentrations of 150 ppm available chlorine, do not exceed contact time of 20 minutes, and do not exceed temperatures of 104°F (40°C).

Corrosion discoloration, deposits or pitting may occur under product deposits or under gaskets. Keep surfaces clean, including those under gaskets or in grooves or tight corners. Clean immediately after use. Do not allow equipment to set idle, exposed to air with accumulated foreign material on the surface.

Corrosion pitting may occur when stray electrical currents come in contact with moist stainless steel. Ensure all electrical devices connected to the equipment are correctly grounded.

Elastomer Seal Replacement Following Passivation

Passivation chemicals can damage product contact areas of this equipment. Elastomers (rubber components) are most likely to be affected. Always inspect all elastomer seals after passivation is completed. Replace any seals showing signs of chemical attack. Indications may include swelling, cracks, loss of elasticity or any other noticeable changes when compared with new components.

Introduction

This manual contains installation, operation, cleaning, repair instructions, and parts lists for the C-Series Centrifugal Pumps. It also provides a troubleshooting chart to help in determining and correcting possible pump problems.

The C-Series Centrifugal Pumps consist of two sections, the motor assembly and the pump components (Figure 1 and Figure 2, below). The pump is mounted on the drive motor with an adapter, and is coupled to the motor with a stainless steel stub shaft. The pump impeller mounts on the stub shaft and is secured with a floating impeller retainer pin.

The casing is joined to the adapter by a clamp to simplify removal. This design style also permits the casing outlet to be rotated to various positions. (The C-100 is secured with two wing nuts and may only be mounted with the outlet facing straight up.) The Type "D" seal ensures a long wear life. The Type "D" seal is a standard mechanical external balanced seal. The drive motor is mounted on a frame with adjustable legs in accordance with sanitary design requirements. This configuration also provides for simple installation and easy leveling of the pump.

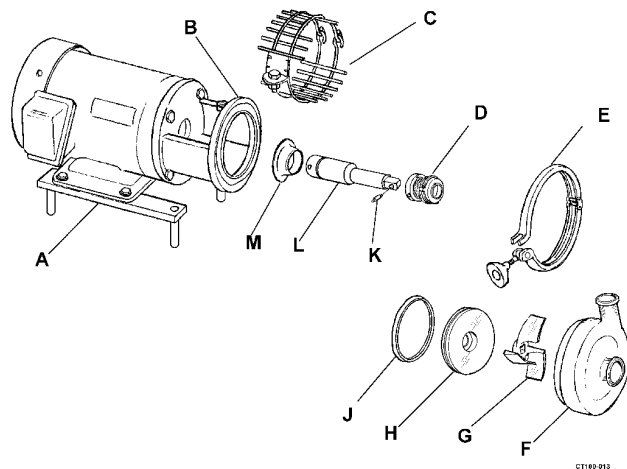

Figure 1 - Pump Components for C-114 through C-328

- A. Motor Leg Mount
- B. Adapter
- C. Guard
- D. Type "D" Seal Assembly
- E. Clamp
- F. Casing
- G. Impeller
- H. Backplate
- J. Backplate Gasket
- K. Impeller Retainer
- L. Stub Shaft
- M. Deflector

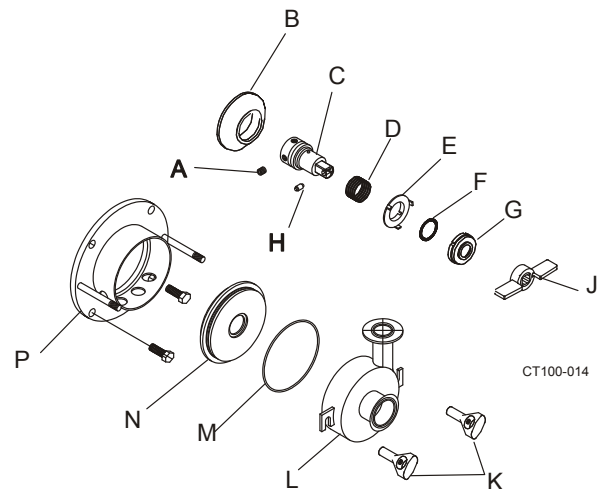

Figure 2 - Pump Components for C-100

- A. Shaft Setscrew
- B. Deflector
- C. Stub Shaft
- D. Spring
- E. Cup
- F. O-ring
- G. Seat Seal
- H. Impeller Retainer
- J. Impeller
- K. Wing Nut
- L. Casing
- M. Backplate Gasket
- N. Backplate
- P. Adapter

Operating Parameters

Capacity:	0 To 780 gpm
Viscosity:	0 To 1500 cPs
Maximum operating temperature:	212°F (100°C)
Maximum inlet pressure:	25 psi (1.7 bar)
Operating Speeds:	1 to 2950 RPM - 50Hz 1 to 3500 RPM - 60Hz

Casing, backplate and impeller are 316 stainless steel with polished sanitary finish.

- Port Connection: S-Line clamp fittings are standard.
- Power: Supplied by a standard foot-mounted C-face motor, through 60 Horsepower.
- Seal Type "D": Seal material is carbon rotating on stationary stainless steel backplate. A water cascading attachment is an available option. See item 137 on page 27.
- Seal Type "DG": Gland ring with replaceable seal seat, used with Type "D" seal. See page 34.
- Seal Type "E": Water-cooled balanced double seal (carbon). See page 35.
- Sanitary Polish: 150 Grit (32 RA) Finish
- Fluoroelastomer o-rings

Pump Dimensions

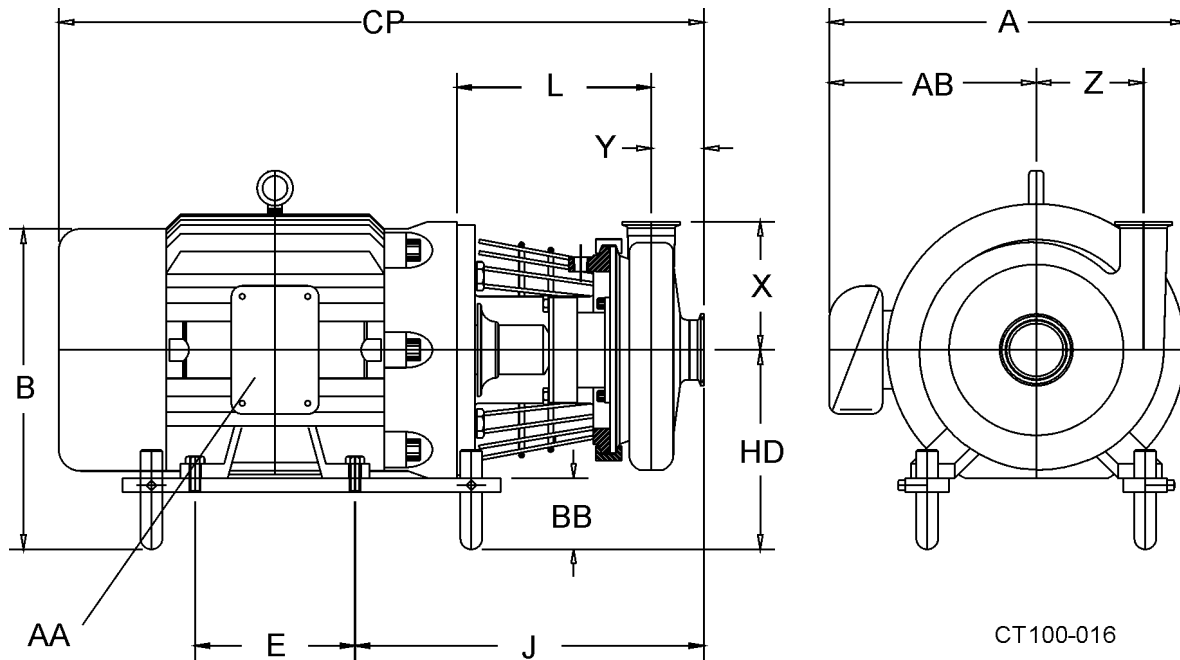

AA= Conduit Size, BB height = 2 1/2" +/- 1" (63.5 +/- 25.4 mm)

Figure 3 - Pump Dimensions with NEMA Motor

Table 1: Callouts for Figure 3 - Pump Dimensions with NEMA Motor

Pump Model	NEMA Frame	A	B	CP	J	E	L	HD	AA	AB
C100	56C	6-1/2" (165 mm)	9-7/32" (241 mm)	17-5/8" (447 mm)	6-7/8" (174 mm)	3" (76 mm)	2-3/4" (70mm)	5-1/2" (139 mm)	1/2" (12 mm)	3-1/4" (82 mm)
	143TC	9-11/16" (246 mm)	9-1/2" (241 mm)	19-31/32" (507 mm)	7- 11/16" (195 mm)	4" (101 mm)	3-3/4" (95 mm)	6" (152 mm)	3/4" (19 mm)	6-15/16" (176 mm)
C114	56C	6-1/2" (165 mm)	9-7/32" (241 mm)	16-11/16" (415 mm)	10-3/8" (263 mm)	3" (76 mm)	6-7/32" (158 mm)	5-1/2" (139 mm)	1/2" (12 mm)	3-1/4" (82 mm)
	140TC	9-11/16" (246 mm)	9-1/2" (241 mm)	19-1/4" (488 mm)	10-11/16" (271 mm)	5" (127 mm)	6-7/32" (158 mm)	6" (152 mm)	3/4" (19 mm)	6-15/16" (176 mm)
	182TC	11-5/8" (295 mm)	11-7/16" (290 mm)	22-1/4" (565 mm)	12" (340 mm)	5-1/2" (139 mm)	6-25/32" (172 mm)	6-31/32" (177 mm)	3/4" (19 mm)	7-7/8" (200 mm)
C216	140TC	9-11/16" (246 mm)	9-1/2" (241 mm)	19-1/4" (488 mm)	10-27/32" (275 mm)	5" (127 mm)	6-1/16" (154 mm)	6" (152 mm)	3/4" (19 mm)	6-15/16" (176 mm)
	180TC	11-5/8" (295 mm)	11-7/16" (290 mm)	22-1/4" (565 mm)	12-7/32" (310 mm)	5-1/2" (139 mm)	6-11/16" (170 mm)	6-31/32" (177 mm)	3/4" (19 mm)	7-7/8" (200 mm)
	210TC	13-1/8" (333 mm)	12-15/16" (328 mm)	25-13/16" (655 mm)	13-31/32" (354 mm)	6" (152 mm)	7-13/16" (198 mm)	7-23/32" (196 mm)	3/4" (19 mm)	8-7/8" (225 mm)
	250TC	14-1/2" (368 mm)	15-1/32" (381 mm)	31-1/16" (788 mm)	14-1/2" (368 mm)	10" (254 mm)	8-1/2" (216 mm)	8-3/4" (222 mm)	1" (25 mm)	9-1/2" (241 mm)
C218 C328	140TC	9-11/16" (246 mm)	9-1/2" (241 mm)	19-1/4" (488 mm)	11" (279 mm)	5" (127 mm)	6-5/16" (160 mm)	6" (152 mm)	3/4" (19 mm)	6-15/16" (176 mm)
	180TC	11-5/8" (295 mm)	11-7/16" (290 mm)	22-1/4" (565 mm)	12-9/32" (312 mm)	5" (127 mm)	6-15/16" (176 mm)	6-31/32" (177 mm)	3/4" (19 mm)	7-7/8" (200 mm)
	210TC	13-1/8" (333 mm)	12-15/16" (328 mm)	25-13/16" (655 mm)	13-9/32" (337 mm)	6" (152 mm)	7-5/16" (185 mm)	7-23/32" (196 mm)	3/4" (19 mm)	8-7/8" (225 mm)
	250TC	14-1/2" (368 mm)	15-1/32" (381 mm)	31-1/16" (788 mm)	14-21/32" (372 mm)	10" (254 mm)	8-3/16" (208 mm)	8-3/4" (222 mm)	1" (25 mm)	9-1/2" (241 mm)
	280TC	20-5/8" (524 mm)	17-9/32" (439 mm)	32-1/4" (819 mm)	15-9/32" (388 mm)	11" (279 mm)	8-13/16" (224 mm)	9-1/2" (241 mm)	2" (50 mm)	13-1/8" (333 mm)
	320TC	23-1/8" (587 mm)	21" (533 mm)	35-7/16" (900 mm)	17-5/32" (435 mm)	12" (304 mm)	9-11/16" (246 mm)	10-1/2" (266 mm)	2" (50 mm)	14-1/8" (358 mm)

Table 2: Callouts for Figure 3 - Pump Dimensions with NEMA Motor

Model	Suction	Discharge	X	Y	Z
C100	1 1/2" (38 mm)	1" (25 mm)	3 1/2" (88 mm)	1 1/2" (38 mm)	1 29/64" (37 mm)
C114	1 1/2" (38 mm) OR 2" (51 mm)	1 1/2" (38 mm)	3 5/8" (92 mm)	1 5/8" (41 mm)	2 5/8" (66 mm)
C216	2" (51 mm) OR 2 1/2" (63 mm)	1 1/2" (38 mm)	4 1/2" (144 mm)	1 15/16" (49 mm)	3 11/16" (93 mm)
C218	2" (51 mm) OR 3" (76 mm)	1 1/2" (38 mm)	5 1/2" (139 mm)	1 15/16" (49 mm)	4 3/4" (120 mm)
C328	3" (76 mm) OR 4" (101 mm)	2" (51 mm)	5 1/2" (139 mm)	2 1/4" (57 mm)	4 3/4" (120 mm)

NOTE: Dimensions are for guidance only. Contact your SPX Representative for more detailed measurements if needed.

Table 3: Mechanical Specifications and Available NEMA Motor Frame Sizes

Pump Model	PORT SIZE		IMPELLER DIAMETER		Available NEMA Motor Frame Size
	Inlet	Discharge	Minimum	Maximum	
C-100	1 1/2" (38 mm)	1" (25 mm)	3" (76 mm)	3 11/16" (93 mm)	56C 140TC
C-114	1 1/2" (38 mm) 2" (51 mm)	1 1/2" (38 mm) 1 1/2" (38 mm)	2 1/2" (63 mm)	4" (101 mm)	140TC 180TC
C-216	2" (51 mm) 2 1/2" (63 mm)	1 1/2" (38 mm) 1 1/2" (38 mm)	4" (101 mm)	6" (152 mm)	56C-140TC 180TC 210TC 250TC
C-218	2" (51 mm) 3" (76 mm)	1 1/2" (38 mm) 1 1/2" (38 mm)	6" (152 mm)	8" (203 mm)	140TC 180TC 210TC 250TC 280TC
C-328	3" (76 mm) 4" (101 mm)	2 1/2" (51 mm) 2 1/2" (51 mm)	5 1/2" (139 mm)	8" (203 mm)	180TC 210TC 250TC 280TC 320TC

Installation

Unpack all parts of your equipment and inspect for damages that may have occurred during shipping. Report any damage to the carrier. See “Shipping Damage or Loss” on page 2.

All ports are covered at the factory to keep out foreign objects during transit. If the covers are missing or damaged, remove the pump cover and thoroughly inspect the fluid head. Be sure the pumping head is clean and free of foreign material before rotating the shaft.

Pump Location

1. Locate the pump as near as practical to the liquid supply.
2. Keep the supply piping short and straight to keep the pump supplied with liquid and prevent damaging cavitation.
3. Locate the pump so that it is accessible for service and inspection during operation.
4. Protect the motor from flooding.

Pump Leveling

Level the pump by loosening the setscrews (see Figure 4, item A) to adjust the length of the legs.

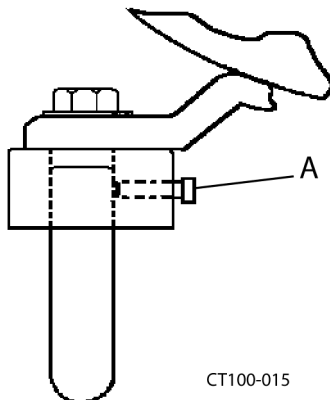

Figure 4 - Leveling Leg Setscrew Location

Supply and Discharge Piping/Valves

- Use a line size equal to or larger than the connection size on the pump, especially the inlet supply line.
- Keep the supply line as short and straight as possible by minimizing the use of elbows and valves. Avoid up and down rises that trap air.
- Be certain all joints in the suction line are well-sealed to prevent air leaks.
- Maintain a straight length of pipe (see Figure 5, item A) at least 8 diameters long at the pump inlet.

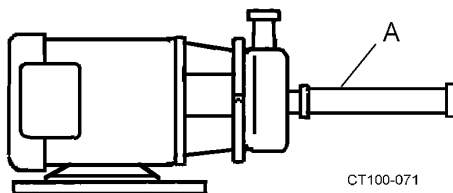

Figure 5 - Straight Pipe Length

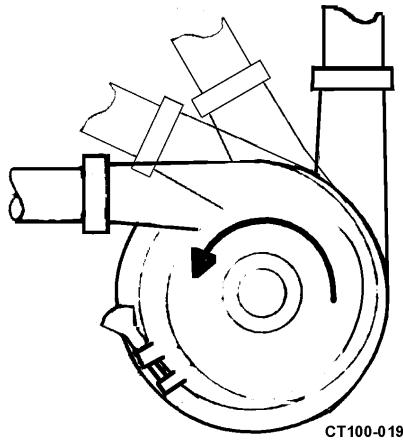

Figure 6 - Recommended Discharge Positions

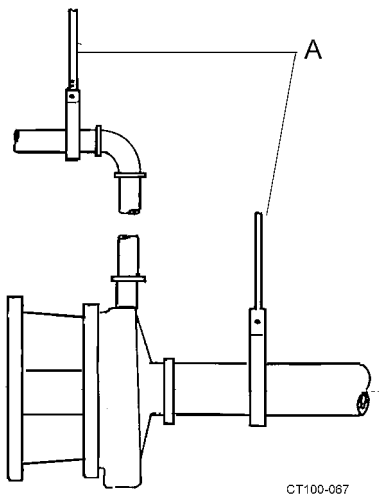

Figure 7 - Pipe Supports

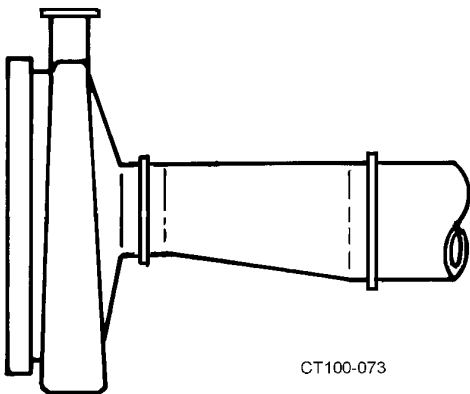

Figure 8 - Correct Eccentric Installation

- The pump casing may be rotated with the discharge connection pointing in any direction; the best pump performance will be with the outlet up, to the left, or positions in between. These positions ensure a flooded casing and prevent problems caused by air in the system. See Figure 6.
- Seal all joints in the suction line well to prevent air from being sucked into the system.
- Support the supply and discharge piping near the pump so that no strain is put on the pump casing.
- If an expansion joint is used, install a pipe anchor between it and the pump.
- If a reducer is connected to the inlet, use an eccentric type to prevent problems due to trapped air. See Figure 8.
- The slope of the line depends on the application requirements; the best pump operation is with the supply line sloped slightly upward toward the pump to prevent trapped air. If the system must drain into the pump casing, keep the downward slope to a minimum or priming problems may occur.
- Install shutoff valves to isolate the pump from the supply and discharge lines to allow the pump to be serviced without draining the system.



CAUTION: The pump and piping may contain sharp edges. Wear gloves to help avoid injuries from these hazards.

- This pump is not self-priming. If the pump is installed above the supply liquid level, install a foot valve or other system check valve to keep the system flooded for priming (see Figure 9, item A).
- A throttling valve may be required to control the pump flow rate to prevent motor overload. Always install a throttling valve (see Figure 9, item B) in the discharge piping and at least 10 diameters from the pump outlet. **NEVER** install a throttling valve in the supply piping.

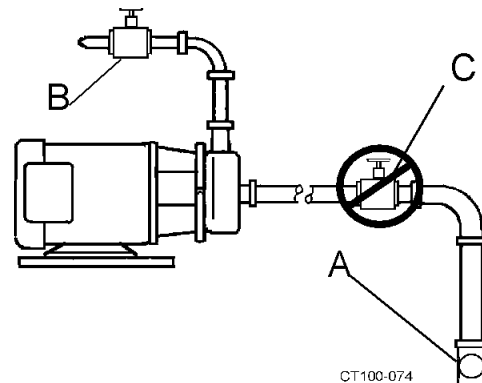

Figure 9 - Valve Piping Installation

Installations That May Cause Operation Problems

- Any system throttling valves or similar devices to control flow rate must be installed in the **discharge** line. **DO NOT** install any system throttling valves or similar devices to control the flow rate in the **supply** line. Restriction in the supply line may cause cavitation and pump damage.
- “Water hammer” in the system can damage the pump and other system components. Water hammer often occurs when valves in the system are suddenly closed, causing lines to move violently with a loud noise. One way to eliminate water hammer is to slow down the actuation speed of the valve.
- Do not expose the pump to freezing temperatures with liquid in the casing. Frozen liquid in the casing will damage pump. Drain the casing before exposing it to freezing temperatures.

Electrical Connections

- Read the motor manufacturer's instructions before making an installation. Follow the manufacturer's lubrication schedules.

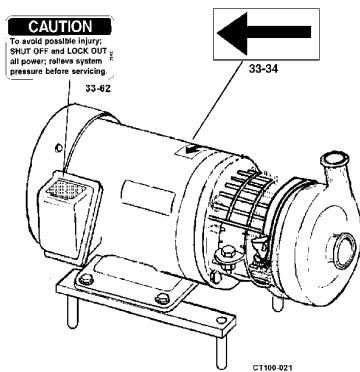

Figure 10 - Replaceable Label Location

WARNING: To avoid electrocution, ALL electrical installation should be done by a registered Electrician, following Industry Safety Standards. All power must be OFF and LOCKED OUT during installation.

- Check the motor nameplate to be sure that the motor is compatible with the electrical supply and all wiring, switches, and starters. Make sure all overload protections are correctly sized.
- Check the pump rotation following an electrical installation. The correct direction of rotation is counterclockwise when facing the pump inlet connection. See Figure 6 on page 10.

Flush Seal Option

When this option is ordered, a fitting assembly (see Figure 11, item A) is supplied for directing a flow of water onto the backplate/ seal area.

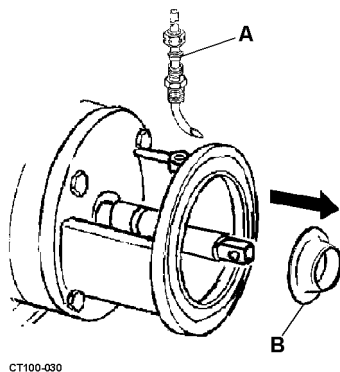

Figure 11 - Cascade System Installation

- The water cascade (see Figure 11, item A) mounts in the adapter above the seal on the assembled backplate to flow water onto the seal face.
- The connection is 1/4 inch .O.D. tubing.
- The required flow is approximately 5 U.S. gallons per hour (3.79 liters per hour).
- The recommended water supply is cool and filtered. If the product solidifies at cool temperature, warm or hot water can be used.

Before First Startup

Cleaning Safety Procedures



WARNING: To prevent an accidental start-up, lock out the power source using your lock and key.

Clean Pump and Piping

Disassemble the pump and clean all product contact parts and seal parts prior to first operation. Follow instructions in the “Cleaning Safety Procedures” on page 12 and “Pump Disassembly” on page 15. Thoroughly clean the pump of any materials that could have accumulated during installation.

Manual Cleaning

- Do not use toxic and/or flammable solvents.
- Lock out electrical power and shut off all air prior to cleaning the equipment.
- Keep electrical panel covers closed and power off when washing the equipment.
- Clean up spills as soon as possible.
- Never attempt to clean the equipment while it is operating.
- Wear proper protective clothing.

Cleaning-In-Place (CIP)

1. Make certain that all connections in the cleaning circuit are properly applied and tightened to avoid contact with hot water or cleaning solutions.
2. When the cleaning cycle is controlled from a remote or automated cleaning center, establish safe procedures to avoid automatic start-up while servicing equipment in the circuit.

Preliminary Test Run

Test the system using a preliminary run with the materials that will be pumped. **DO NOT** run the pump to produce final product at this time. See “Starting the Pump” on page 13.

Check for Possible Motor Overload Condition

Certain combinations will overload the motor when operated with open unrestricted discharge, resulting in an unacceptably high flow rate. Additional discharge restriction may be required to lower the flow rate and lower the horsepower requirement. **DO NOT** add any restriction to the supply line. If the pump was incorrectly selected, a smaller impeller or a higher motor horsepower may be required. If you are uncertain about pump selection and application, temporarily install an ammeter in the electrical service.

Ammeter Test

Operate the pump under process conditions and check the motor amp draw versus the nameplate full load rating. If the amp draw exceeds the motor rating, a system change or pump change is required. If the process conditions and/or liquid changes (higher viscosity, higher specific gravity), recheck the motor amp draw. Contact your authorized SPX distributor for assistance.



WARNING: To avoid electrocution and equipment damage, only a qualified electrician should install the ammeter.

Operation

Ensure that the pump is correctly installed as described in “Installation” on page 9.

Starting the Pump

1. If the pump has a flush seal option, start the flow of flush water (recommended rate is approximately 5 US gallons per hour) before operating the pump.
2. **Before starting the pump**, prime the pump by flooding the pump casing with liquid to avoid damaging the pump parts. Depending on the installation, refer to either:
 - “Priming the Pump with the Feed Source Above Pump Level” on page 13, or
 - “Priming the Pump with the Feed Source Below Pump Level” on page 14.
3. Start the pump motor.
4. Check the pump to ensure that the liquid is flowing and that all piping connections and seals are leak-free.
5. Make sure that the pump is not operating against a closed discharge. Continued operation against a closed discharge will heat the liquid in the casing to boiling and lead to pump damage.
6. Slowly open the discharge valve until the desired flow is obtained. Observe the pressure gauges. If pressure is not attained quickly, stop the pump and prime it again.

Priming the Pump

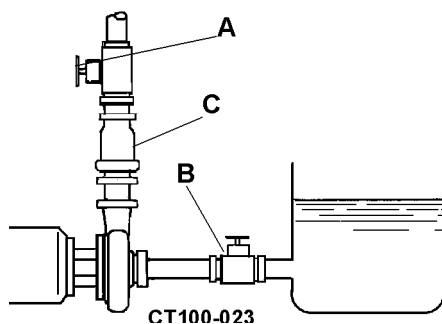

**Figure 12 - Pump Below Supply
(Feed Source Above Pump Level)**

Priming the Pump with the Feed Source Above Pump Level

1. Fill the supply tank with liquid and open the supply line (suction) valve (see Figure 12, item B).
2. Open the discharge valve to vent any air trapped in the supply line or casing (see Figure 12, item A).
3. Resume the “Starting the Pump” procedure on page 13, at step 3.

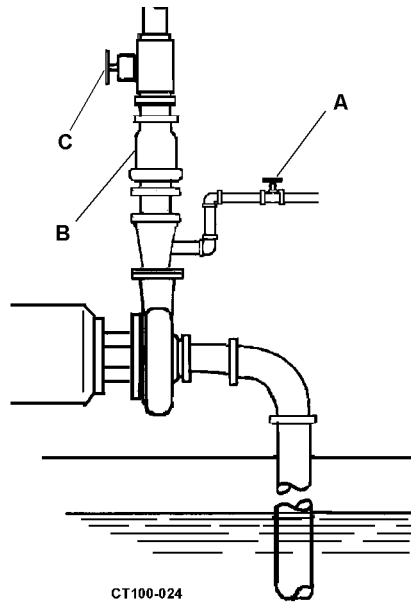

**Figure 13 - Pump Above Supply
(Feed Source Below Pump Level)**

Priming the Pump with the Feed Source Below Pump Level

The pump will not self-prime if the liquid supply is below the pump level. If the liquid supply is below the pump level, provide an outside source for priming.

1. Close the discharge valve (see Figure 13, item C) and open the air vents.
2. Open the valve in the outside supply line (see Figure 13, item A) until liquid flows from the vent valves.
3. Close the vent valves.
4. Close the outside supply line.

NOTE: Use a type of check valve system (see Figure 13, item B) to keep the supply line and pump casing flooded with liquid; otherwise the pump must be primed before each operation.

5. Resume the “Starting the Pump” procedure on page 13, at step 3.

Stopping the Pump

1. To stop the pump, shut off power to the pump motor.

NOTE: Liquid in the system can flow freely through the pump; the pump does not act as a shutoff valve.

2. Shut off the supply and discharge lines.

Maintenance

Scheduled Maintenance

A routine maintenance program can extend the life of your pump. Keep maintenance records. These will help pinpoint potential problems and causes.

Routine Maintenance

- Check for unusual noise, vibration and bearing temperatures.
- Inspect the pump and piping for leaks.
- Check the mechanical seal area for leakage (no leakage is desired).
- Check the backplate gasket for wear/damage.
- Lubricate the bearings (see motor manufacturer for correct specifications).
- Monitor the seals.
- Perform vibration analysis.
- Check the discharge pressure.
- Monitor the temperature.

Pump Disassembly

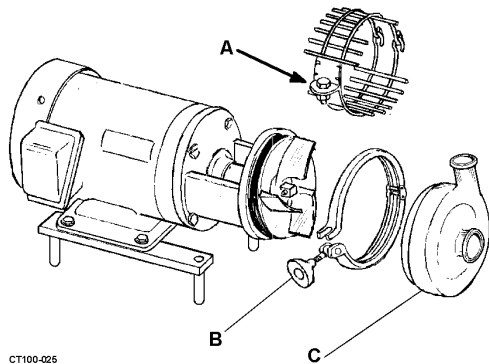

Figure 14 - Casing Assembly

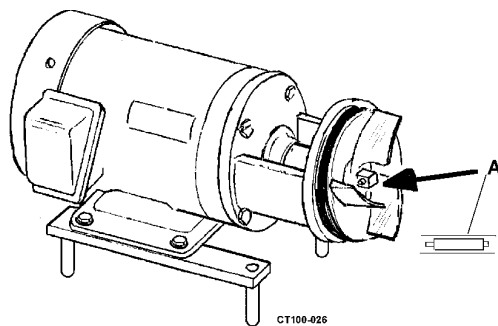
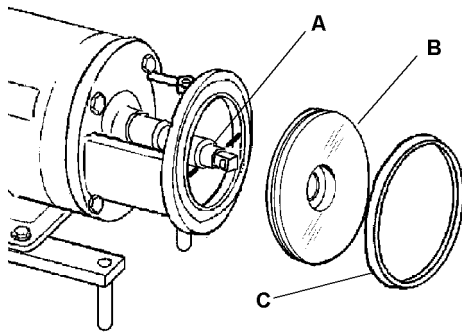

Figure 15 - Impeller Retainer Pin

1. Shut off the product flow to the pump and relieve any product pressure.
 2. Shut off and lock out power to the pump.
 3. Disconnect the suction and discharge pipe fittings.
 4. Using a wrench, remove the seal guard assembly (see Figure 14, item A).
 5. Loosen the clamp wing nut and swing the clamp open.
- NOTE:** On the C-100, remove the casing wing nuts.
6. Remove the casing and inspect the clamp saddles and the casing for damage or wear. Replace if necessary. (See Figure 14, item B and C.)
 7. Push back on the impeller and position the retaining pin in the center of the stub shaft. This will allow the impeller to be pulled off the stub shaft.



CT100-027

Figure 16 - Backplate Gasket

8. Rotate the backplate to disengage the backplate pins from the adapter pins. Remove the backplate with the gasket attached (see Figure 16, item B and C), by pulling it straight off the adapter. (See Figure 16, item A.)
9. Remove the backplate gasket and inspect it for wear and sealing failure.

NOTE: Take care to protect the sealing face and edges of the backplate from nicks and scratches.

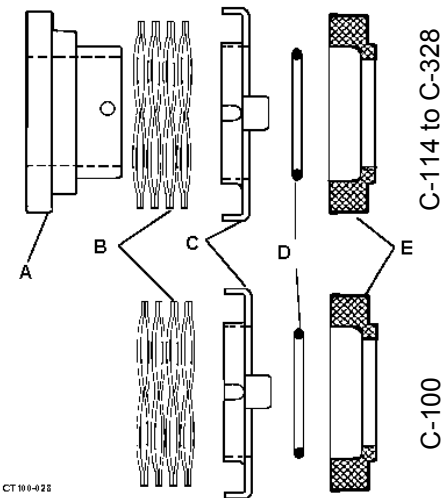

CT100-028

Figure 17 - Seal Arrangement

1. Pull the carbon seal, o-ring, seal cup, and spring straight off the stub shaft to remove them. (See Figure 17.)
2. Carefully inspect the o-ring (Figure 17, item D) and the carbon seal (Figure 17, item E) for signs of abrasions, cuts, or other wear that could cause leakage.

NOTE: When the extension end of the carbon seal is less than 1/32" (see Figure 18, item A), replace the seal.

3. After cleaning, inspect the seal, o-ring, and gasket again. Replace as necessary.

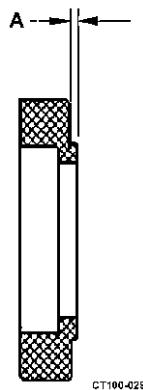

CT100-029

Figure 18 - Carbon Seal Measurements

4. Remove the water cascade attachment from the adapter (if included). See Figure 19, item A. Remove the rubber shaft deflector (Figure 19, item B) by pulling it straight off the stub shaft. Examine it for tearing, loose fit, or other defects that would allow liquid to leak into the motor along the shaft.

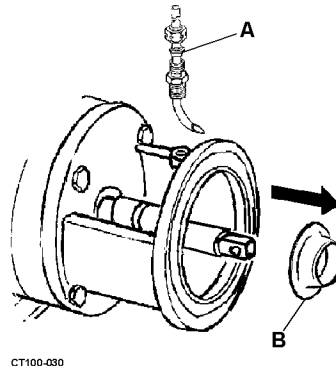

CT100-030

Figure 19 - Removal of Cascade System

Replacing the Motor

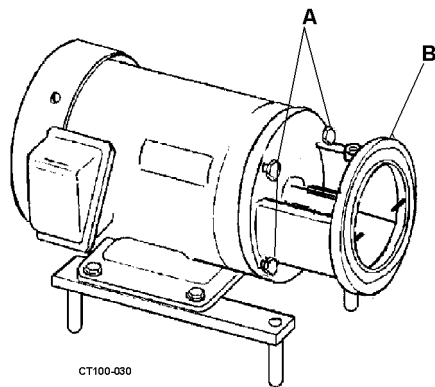

Figure 20 - Removing the Adapter

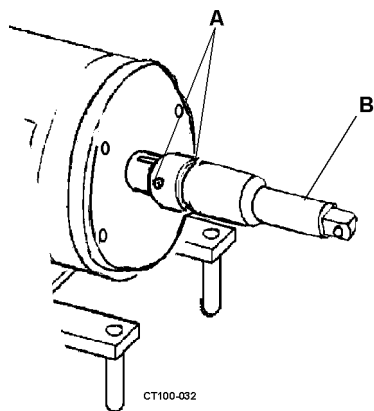

Figure 21 - Stub Shaft Removal

Installing the Adapter

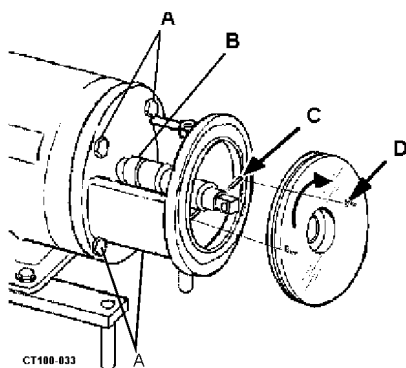

Figure 22 - Adapter Installation

1. To replace or service the motor, disassemble the pump as outlined in "Pump Disassembly" on page 15.
2. Remove the bolts securing the adapter (Figure 20, items A and B) to the motor frame and remove the adapter.
3. Loosen the two setscrews securing the stub-shaft to the motor shaft (see Figure 21, items A and B). Carefully remove the stub-shaft. The stub-shaft is a tight fit, but can be removed by applying pressure around the periphery of the shaft with a pry bar.

NOTE: Examine the shaft sealing surfaces for nicks or scratches which can cause excessive o-ring wear or leaking.

4. Remove the bolts securing the motor to the mounting brackets. Bolt the new motor to the mounting brackets.

NOTE: Motor maintenance, repair and wiring are not covered in this manual. For specific information, contact the motor manufacturer.

5. If required, level the motor by adjusting the legs individually and securing them in place with the setscrews. See "Pump Leveling" on page 9.

1. Install the adapter to the motor, with the drain cavity at the bottom. Insert the four bolts to secure the adapter to the motor. Tighten the bolts. (See Figure 22, item A.)
2. Install the key in the motor shaft.
3. Place the stub-shaft assembly onto the motor shaft. (See Figure 22, item B.) **Do not tighten the shaft setscrews.**
4. Install the backplate on the adapter and rotate it until the backplate pins engage the adapter pins (see Figure 22, items D and C), ensuring solid contact of the backplate to the adapter.
5. Rotate the stub shaft until the impeller retaining hole is in a horizontal position. Insert the impeller retainer pin, and center it in the stub-shaft.
6. Slide the impeller onto the shaft. Hold the impeller tight against the shoulder in the shaft and rotate the shaft one-quarter turn until the impeller pin engages with the impeller. See Figure 23 on page 18.

Stub Shaft Adjustment

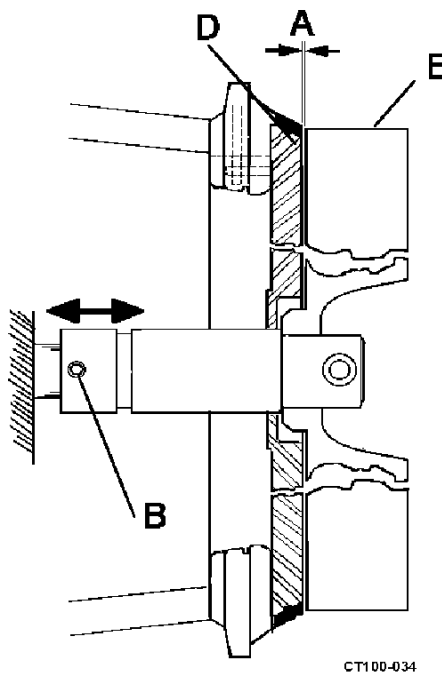

Figure 23 - Setting Backplate/Impeller Clearance

1. Place a 0.060" ± 0.010" (1.52 mm ± 0.25 mm) feeler gauge between the front face of the backplate and the impeller. (See Figure 23, item A.)
2. Push the stub-shaft/impeller assembly toward the motor until the impeller (Figure 23, item E) rests against the feeler gauge.
3. Tighten the two setscrews on the stub-shaft. (See Figure 23, item B.)
4. With a feeler gauge, check that the clearance between the rear face of the impeller and the front (inside) face of the backplate is 0.060" ± 0.010" (1.52 mm ± 0.25 mm). (See Figure 23, item A.)
5. Remove the impeller retainer pin, impeller, and backplate.
6. Slide the deflector (large diameter end first) onto the shaft until it seats in the shaft groove. See Figure 24, item A.

NOTE: If the deflector can not be forced on with the fingers, use a blunt tool to tap it evenly into place.

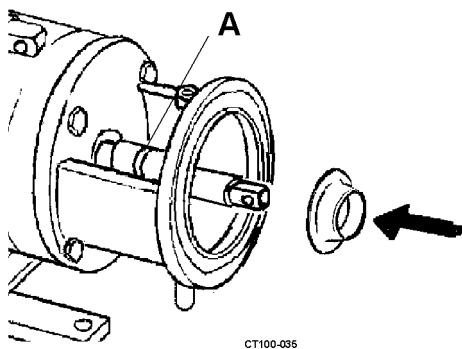

Figure 24 - Installing Deflector

Installing Type "D" Seal

1. Slide the seal drive collar onto the stub shaft as shown in Figure 25. (Does not apply to the C-100; the C-100 does not require a drive collar. Proceed to step 3.)
2. Use the "A" and "B" dimensions in Table 4 to properly locate the drive collar on the stub shaft. See Figure 25. Tighten the setscrews to secure it in place.

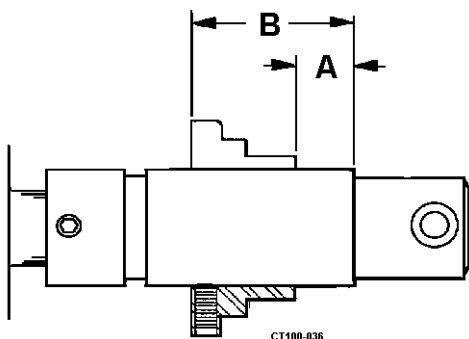

Figure 25 - Drive Collar for "D" Seal Type Adjustment

Table 4: Seal Chart

Model	A	B
C-114	9/16" (14.2mm)	1 7/16" (36.5 mm)
C-216	9/16" (14.2mm)	1 23/32" (43.6 mm)
C-218	9/16" (14.2mm)	1 41/64" (41.6 mm)
C-328	9/16" (14.2mm)	1 41/64" (41.6 mm)

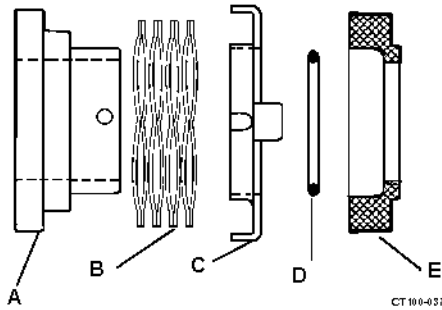

Figure 26 - Carbon Seal

3. See Figure 26. Assemble the spring (item B), seal cup (item C), o-ring (item D) and carbon seal (item E), and install them as a unit, taking care that the slot in the seal cup aligns with the pin on the shaft. Gentle pressure on the o-ring will overcome resistance on the shaft.

NOTE: Do not lubricate seals with any type of oil or grease. The seal faces will be lubricated by the product being pumped.

4. Assemble the gasket to the backplate.
5. Install the backplate on the adapter. Check that the seal cup slot is engaged with the pin on the drive collar. See Figure 27.
6. Rotate the backplate until the backplate pins engage the adapter pins. (See Figure 27, item A and B.)
7. Rotate the shaft until the pin hole in the end is in a horizontal position. Insert the impeller pin (Figure 27, item C), center it in the shaft end, and slide the impeller (Figure 27, item D) onto the shaft.

NOTE: Hold the impeller tight against the stub shaft and rotate the shaft one-quarter turn until the impeller pin drops and secures the impeller.

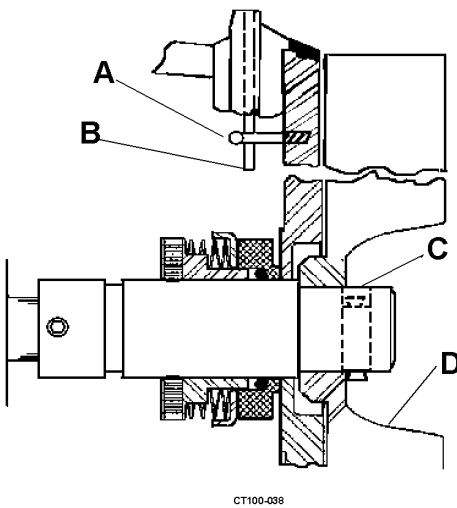

Figure 27 - Backplate Installation

8. Place the casing over the impeller/backplate, then close and tighten the clamp. See Figure 28.

NOTE: Check for strain or misalignment of piping to the casing. Re-adjust the casing ports and/or entire motor, leveling as necessary.

9. Assemble the cascade water fitting (if included). Install the seal guard and tighten it in place. Assemble the suction and discharge lines to the casing.

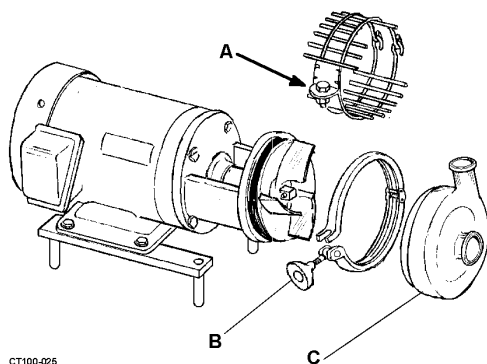

Figure 28 - Casing Clamp Guard Assembly

Type "DG" Seal

The "DG" Seal is similar to the seal type "D", but incorporates a replaceable, clamped-in stationary seal seat.

Disassembly

1. Disconnect the suction and discharge piping.
2. Using a wrench, remove the seal guard assembly (See Figure 14, page 15, item A).
3. Loosen the clamp wing nut and swing the clamp open.
4. Remove the casing and inspect the clamp saddles and the casing for damage or wear and replace if necessary (see Figure 14, items B and C on page 15).
5. Push back on the impeller and position the retaining pin in the center of the stub shaft. This will allow the impeller to be pulled off the stub shaft.
6. Rotate the backplate to disengage the backplate pins from the adapter pins. Remove the backplate with the gasket attached (see Figure 16, items B and C on page 16), by pulling it straight off the adapter. (See Figure 16, item A on page 16.)
7. Remove the backplate gasket and inspect it for wear and sealing failure.
8. Pull the carbon seal, o-ring, seal cup and spring straight off the stub shaft to remove them. See Figure 17 on page 16.
9. Carefully inspect the o-ring (see Figure 17, item D on page 16) and the carbon seal (see Figure 17, item E on page 16) for signs of abrasion, cuts, or other wear that could cause leakage.
10. Remove four nuts and washers off the backplate to release the S.S. Gland ring, Seal Seat and PTFE Gaskets (see Figure 29). Examine them for signs of abrasion, cuts or other wear that could cause leakage and replace as required.

NOTE: Take care to protect the sealing face and edges of the backplate from nicks and scratches.

NOTE: When the extension end of the carbon seal is less than $1/32"$ (0,03 mm) (see Figure 18, item A on page 16), replace the carbon seal.

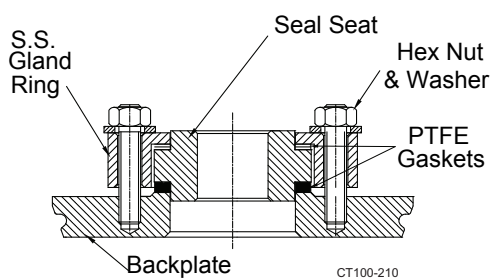

Figure 29 - Stationary Seal Seat

Reassembly

DG stationary seal seats are reversible as supplied by the factory. To reverse, remove the four nuts and washers that secure the gland-ring to the back-plate and lift off the gland ring. The stationary seat can be turned over to bring the unused surface into use.

If the seal has been replaced or the drive collar loosened, it will need to be repositioned.

1. Assemble the PTFE gaskets, seal seat, the S.S. gland ring and washers on the back-plate as shown in Figure 29 and tighten them uniformly with the hex nuts.

NOTE: Teflon gaskets with different thicknesses are used. The thicker gasket must always be installed on the impeller side to prevent contact between the impeller hub and the stationary seat.

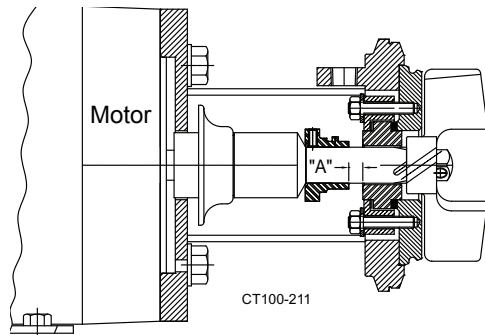

Figure 30 - Drive Collar Adjustment for "DG" Seal

Table 5: Callout dimensions for Figure 30

Model	Dimension "A"
C-114 / C-216	0.295" (7.5 mm)
C-218 / C-328	0.312" (7.9 mm)

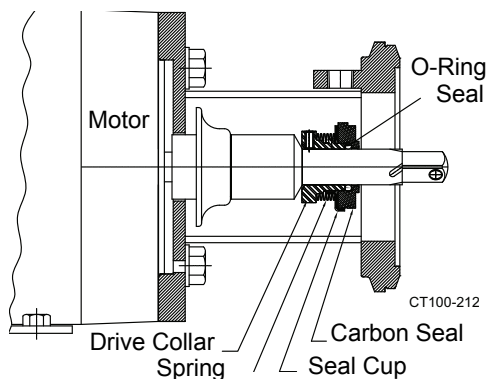

Figure 31 - Installing Seal

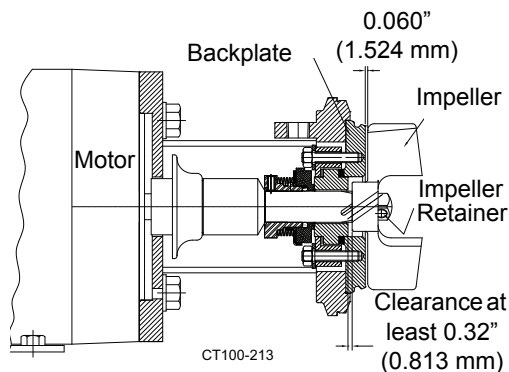

Figure 32 - Installing backplate and impeller

2. Slide the drive collar onto the stub shaft.
3. Install the back plate, gasket casing, and casing.
4. Install and tighten the casing clamp.
5. Using an appropriate tool, set the drive collar to the dimension "A" as shown in Figure 30, and tighten the setscrew of the drive collar.
6. Remove casing clamp, casing and back-plate.
7. Assemble the spring, seal cup, o-ring, and carbon seal onto the drive collar. Take care to ensure that the pin on the drive collar is in line with the slot on the cup. (See Figure 31.)
8. Assemble the back-plate, insert the impeller-retainer on the stub shaft, locating it in the center and install the impeller, tighten against the stub shaft and turn it until the impeller-retainer falls and secure the impeller. (See Figure 32.)
9. Before installing the casing, visually inspect the impeller hub and seal face to ensure that there is clearance between them. If no clearance is visible, disassemble the pump and move the stub shaft forward, to provide at least 0.032" (0.813 mm) clearance between the impeller hub and the seal seat face. (See Figure 32.)
10. Reset the seal drive collar if necessary. When the drive collar is properly positioned and the seal components are properly installed, the pump shaft should rotate freely by hand. If excessive effort is required to rotate the shaft, check to be sure that all components are properly installed.
11. Assemble the casing gasket and casing, and then install the clamp. Use a soft rubber mallet to line up the casing and tighten the clamp, then install the seal guard.

Type “E” Water-Cooled Balanced Double Seal

The Type “E” seal consists of two carbon seals inside a stuffing box that is attached to the backplate. Its sealing action is the same as the external balanced seal. This seal design is used in applications where a vacuum-tight, cool operating seal is required.

Periodically inspect all parts of the pump to prevent malfunctions caused by worn or broken parts.

NOTE: Disassembly for repair is the same procedure as for cleaning.

Seal Servicing

1. Disconnect the water inlet and outlet from the stuffing box.
2. With a wrench of appropriate size, remove the seal guard assembly.
3. Remove the casing and clamp assembly.
4. Remove the four screws that retain the follower to the stuffing box.
5. Slide the stuffing box and backplate assembly forward off the stub shaft.
6. Remove the inboard carbon seal, seal o-ring, cup, and seal spring from the shaft.
7. Loosen the two setscrews and remove the drive collar.
8. Remove the remaining carbon seal, seal o-ring, cup, and follower from the shaft.

Installing the “E” Seal

1. Install the backplate, gasket, and casing. See Figure 27 on page 19.
2. Install and tighten the casing clamp.
3. Scribe a mark on the shaft at location “A” behind the backplate. See Figure 33.
4. Remove the casing clamp, casing, and backplate.
5. Slide the deflector, follower, one carbon seal, one seal o-ring, one seal cup, and drive collar onto the shaft.
6. Locate the drive collar in relation to the scribe mark and secure it to the shaft with the setscrews. See Figure 33.
7. Install the seal spring, seal cup, seal o-ring, and seal onto the shaft. See Figure 35 on page 23.

NOTE: Drive collar location is critical.

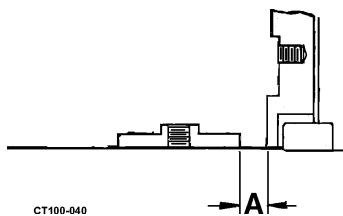

Figure 33 - Drive Collar to Backplate Dimension

Table 6: Callout dimensions for Figure 33

Model	Dimension “A”
C-114	5/16" (7.9 mm)
C-216	23/64" (9.12 mm)
C-218	23/64" (9.12 mm)
C-328	23/64" (9.12 mm)

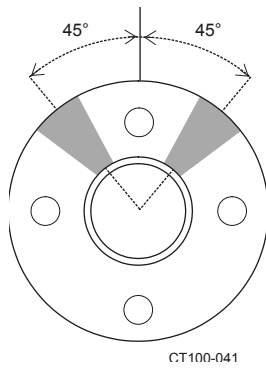

Figure 34 - Water Connection Locations

NOTE: Water must be piped through the stuffing box to keep the seal cool and vacuum-tight.

8. Be sure that the spring is seated in each cup and the drive ear on each seat cup is not in alignment with the drive pins on the drive collar.
9. Slide the stuffing box and backplate assembly over the shaft and seal parts.
10. Secure the follower to the stuffing box using four screws.
11. Assemble the seal guard and tighten the nut.
12. Attach the water inlet and outlet to the stuffing box. Two 1/8" NPT .water connections are provided on the stuffing box. They are spaced at 90° from each other and should be located at 45° to vertical when assembling the pump. Flush water must enter one of these connections and exit through the other.
13. The amount of water used will vary depending on the operating temperature of the pump. In vacuum applications, 10 drops per minute discharge is recommended.

NOTE: Approximately 3 gallons per hour (11.36 liters per hour) is required to maintain the seal temperature at 100°F (38°C) when the product temperature is 175°F (79°C).

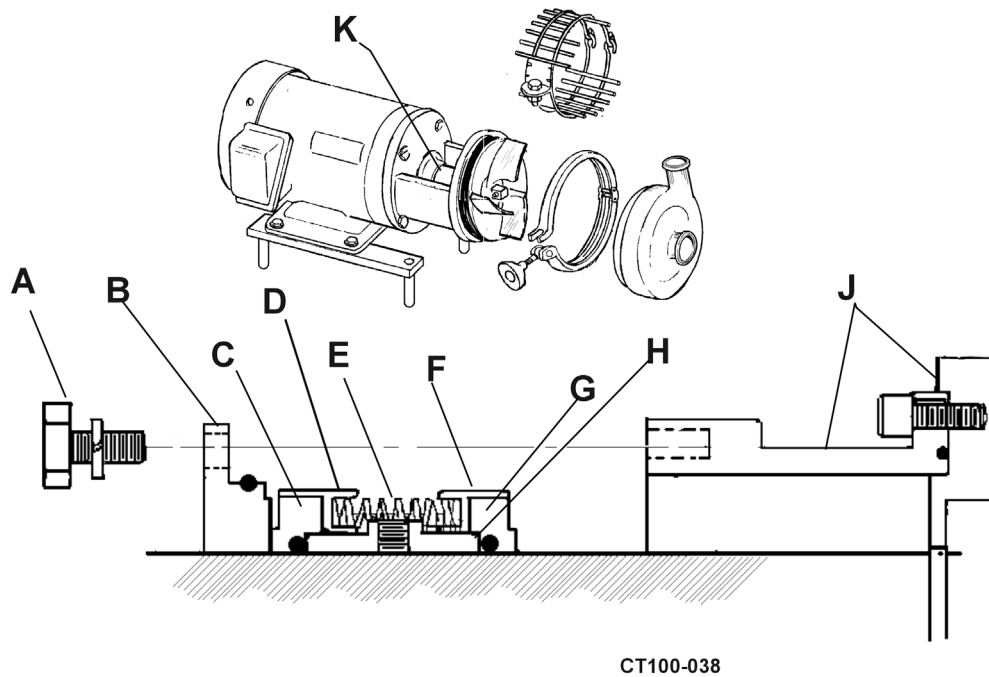

Figure 35 - Parts Stack for Stuffing Box

Table 7: Callouts for Figure 35

A. Four Screws	C. Seal	E. Spring	G. Seal	K. Stuffing Box
B. Follower	D. Cup	F. Cup	H. Drive Collar	J. Stuffing Box and Backplate

Parts Lists

C-100 Pump Parts

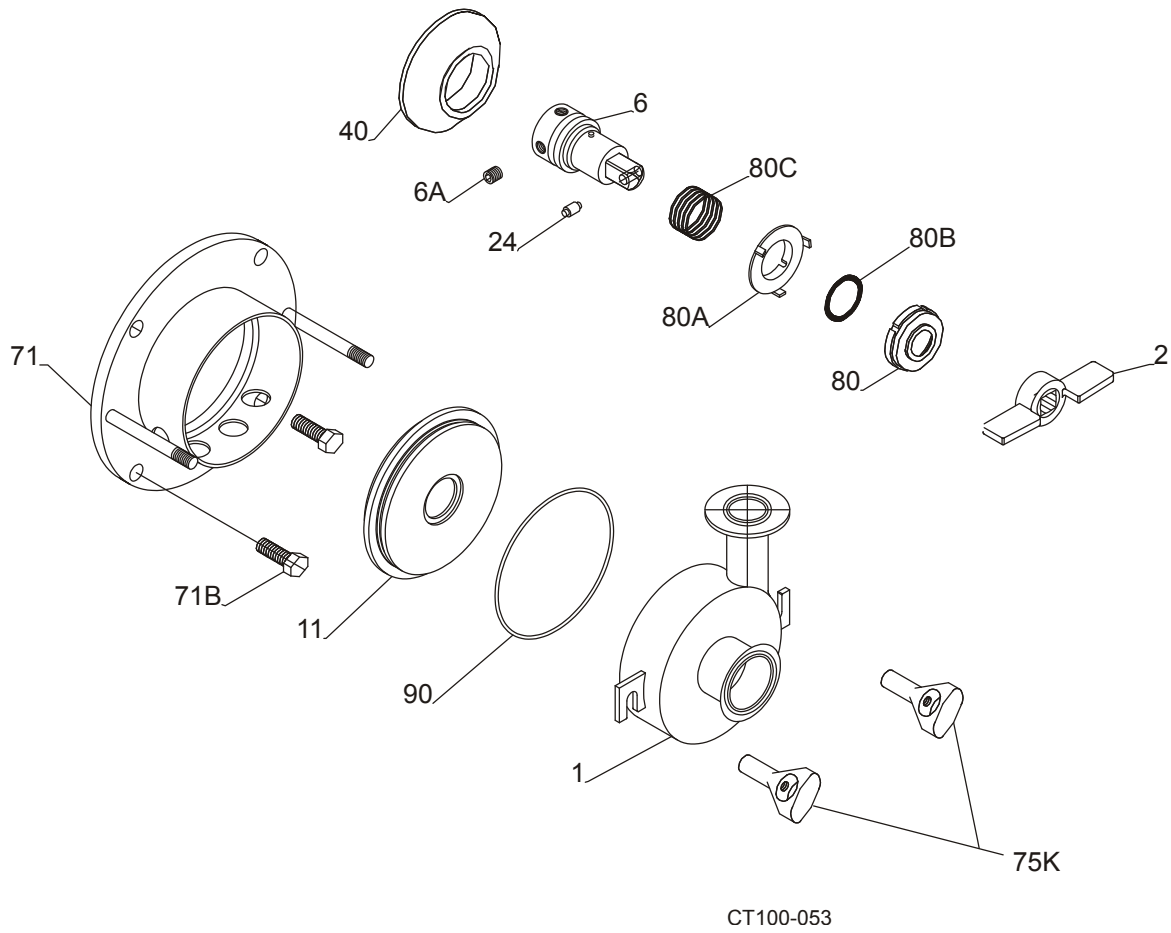

Shown with the standard type "D" seal

C-100 Pump Parts

ITEM NO.	DESCRIPTION	QTY. PER PUMP	PART NO.	NOTES
1	Casing, 1.5" x 1" w/ S-Line Ports	1	60000+	1, 4
2	Impeller, Full 3.68" Diameter	1	60026+	2, 4
6	Stub Shaft, 56C Frame	1	60050+	
	Stub Shaft, 143TC - 145TC Frame	1	60051+	
6A	Shaft Set Screw, 56C-145TC Frame	2	30-22	
11	Backplate	1	60597+	4
* 24	Impeller Retainer	1	60039+	
40	Deflector, 56C - 145TC Frame	1	60042+	
71	Adapter, 56C Frame	1	60596+	
	Adapter, 143TC - 145TC Frame	1	60600+	
71B	Adapter Mounting Bolt, 56C-145TC Frames	4	30-30	
75K	Wing Nut	2	60083+	
* 80	Inboard Rotary Seal, Carbon	1	60084+	
80A	Cup	1	60088+	
* 80B	Seal O-Ring, Buna N	1	N70214	
	Seal O-Ring, FKM	1	V70214	
	Seal O-Ring, EPDM	1	E70214	
80C	Spring	1	60091+	
* 90	Casing O-Ring, Buna N	1	N70153	
	Casing O-Ring, FKM	1	V70153	
	Casing O-Ring, EPDM	1	E70153	

NOTES:

PL5050-CH1

* Recommended Spare Parts - also available in kits (see C-Series Kit Parts List page)

1. For casings with Bevel threaded, Female I-Line, NPT or Flanged connections, please contact factory.
2. Contact factory for trimmed impeller part numbers. Specify diameter required on order.
4. Contact factory if casing drain, passivation, or optional finish is required.

C-114 Pump Parts

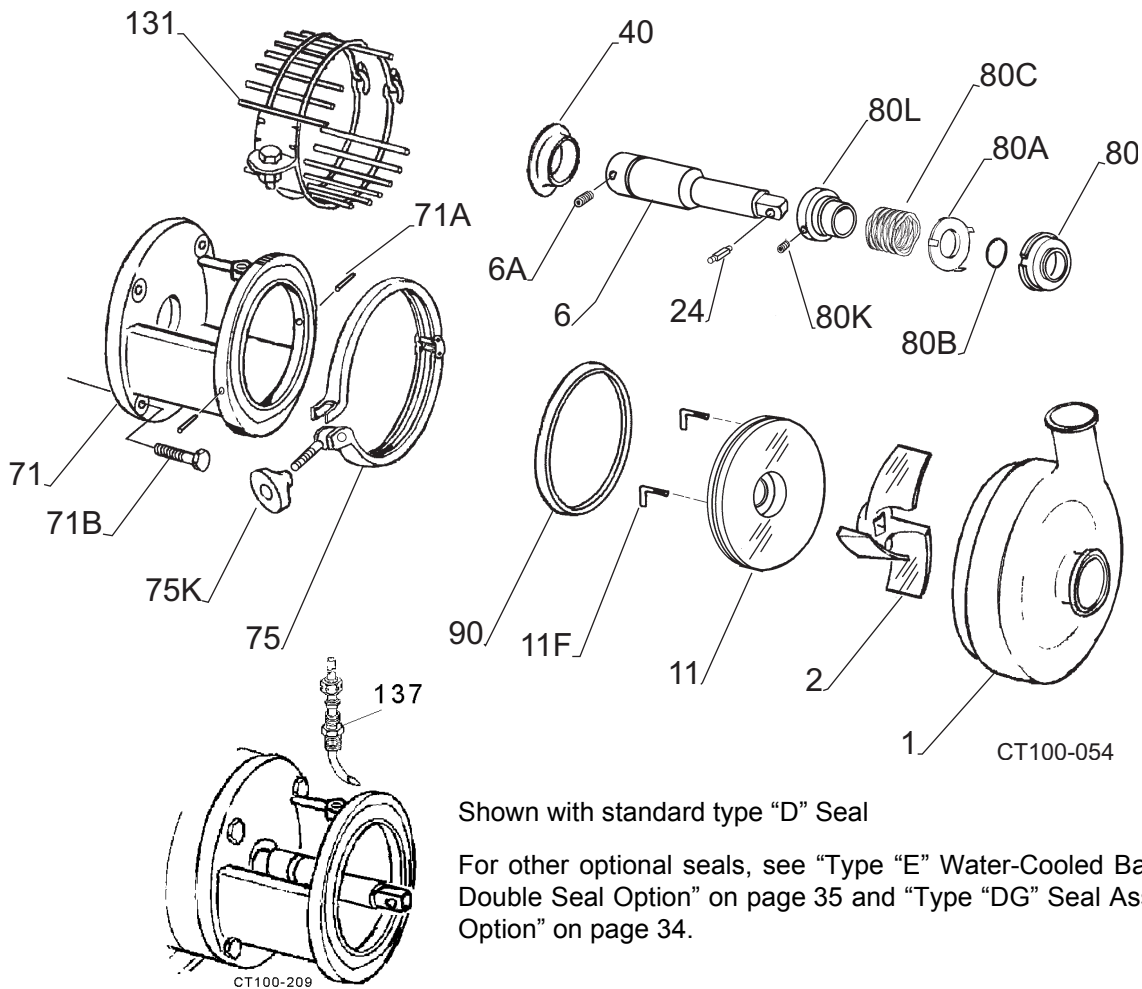

Shown with standard type "D" Seal

For other optional seals, see "Type "E" Water-Cooled Balanced Double Seal Option" on page 35 and "Type "DG" Seal Assembly Option" on page 34.

ITEM NO.	DESCRIPTION	QTY. PER PUMP	PART NO.	NOTES
1	Casing, 1-1/2" x 1-1/2" w/ S-Line Ports	1	60001+	1, 4
	Casing, 2" x 1-1/2" w/ S-Line Ports	1	60002+	1, 4
2	Impeller, Full 4" Diameter	1	60027+	2, 4
6	Stub Shaft, 56C Frame	1	60052+	
	Stub Shaft, 143TC - 145TC Frame	1	60053+	
	Stub Shaft, 182TC - 184TC Frame	1	60054R2	

NOTES:

PL5050-CH2

- * Recommended Spare Parts - also available in kits (see C-Series Kit Parts List page)
- 1. For casings with Bevel threaded, Female I-Line, NPT or Flanged connections, please contact factory.
- 2. Contact factory for trimmed impeller part numbers. Specify diameter required on order.
- 4. Contact factory if casing drain, passivation, or optional finish is required.
- 5. Used with standard "D" seal only.
- 7. Shown with standard type "D" Seal. See "E" and "DG" Seal pages for other seal options.

C-114 Pump Parts

ITEM NO.	DESCRIPTION	QTY. PER PUMP	PART NO.	NOTES
6A	Shaft Set Screw, for 56C-184TC Frame Stub Shafts	2	30-22	
11	Backplate	1	60010+	4, 5
11F	Backplate Pin	2	60013+	
* 24	Impeller Retainer	1	60039+	
40	Deflector, 56C - 145TC Frame	1	60042+	
	Deflector, 182TC - 184TC Frame	1	60043+	
71	304 SS Adapter, 56C - 145TC Frame	1	60748+	
	304 SS Adapter, 182TC - 184TC Frame	1	60749+	
71A	Adapter Pin	2	30-434	
71B	Adapter Mounting Bolt, 56C - 145TC Frame	4	30-60	
	Adapter Mounting Bolt, 182TC - 184TC Frame	4	30-36X	
75	Clamp Assembly	1	60080+	
75K	Wing Nut	1	60083+	
* 80	Inboard Rotary Seal, Carbon	1	60085+	7
80A	Cup	1	60088+	
* 80B	Seal O-Ring, Buna N	1	N70210	
	Seal O-Ring, FKM	1	V70210	
	Seal O-Ring, EPDM	1	E70210	
80C	Spring	1	60091+	
80K	Set Screw	2	30-662	
80L	Drive Collar	1	60094R1	
* 90	Casing Gasket, Buna N	1	60099+	
	Casing Gasket, FKM	1	60100+	
	Casing Gasket, EPDM	1	60626+	
131	Guard Assembly, 56C - 145TC	1	60782+	
	Guard Assembly, 182TC - 184TC Frame	1	60783+	
137	Water Flush Inlet Assembly, optional	1	60112+	

PL5050-CH2b

C-216 Pump Parts

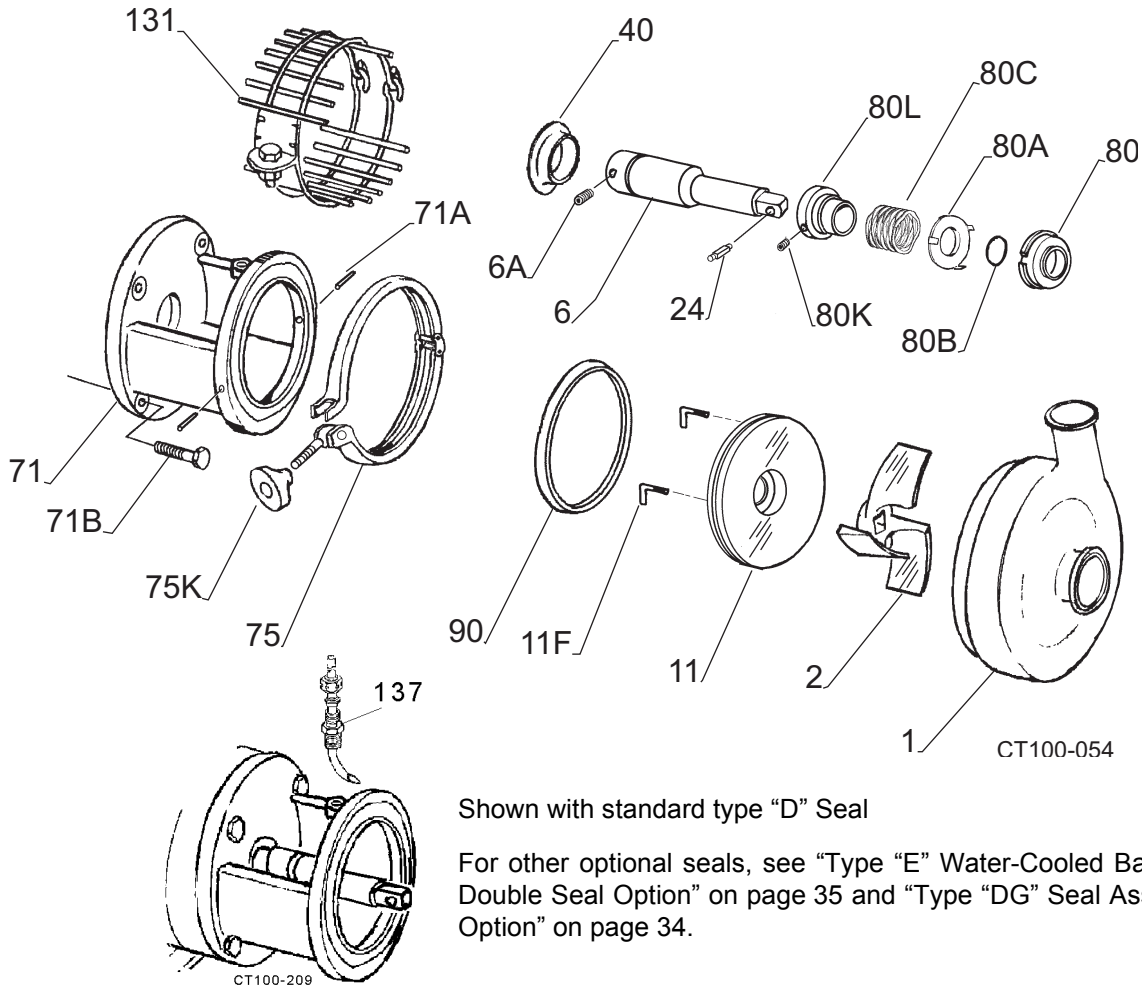

Shown with standard type "D" Seal

For other optional seals, see "Type E" Water-Cooled Balanced Double Seal Option" on page 35 and "Type DG" Seal Assembly Option" on page 34.

ITEM NO.	DESCRIPTION	QTY. PER PUMP	PART NO.	NOTES
1	Casing, 2" x 1-1/2" w/ S-Line Ports	1	60003+	1, 4
	Casing, 2-1/2" x 1-1/2" w/ S-Line Ports	1	60004+	1, 4
2	Impeller, Full 6" Diameter	1	60028+	2, 4
6	Stub Shaft, 56C Frame	1	60055+	
	Stub Shaft, 143TC - 145TC Frame	1	60056+	
	Stub Shaft, 182TC - 184TC Frame	1	60057+	
	Stub Shaft, 213TC - 215TC Frame	1	60058R3	
	Stub Shaft, 254TC - 256TC Frame	1	60059R3	

NOTES:

PL5050-CH3

- * Recommended Spare Parts - also available in kits (see C-Series Kit Parts List page)
- 1. For casings with Bevel threaded, Female I-Line, NPT or Flanged connections, please contact factory.
- 2. Contact factory for trimmed impeller part numbers. Specify diameter required on order.
- 4. Contact factory if casing drain, passivation, or optional finish is required.
- 5. Used with standard "D" seal only.
- 7. Shown with standard type "D" Seal. See "E" and "DG" Seal pages for other seal options.

C-216 Pump Parts

ITEM NO.	DESCRIPTION	QTY. PER PUMP	PART NO.	NOTES
6A	Shaft Set Screw, 56C - 184TC Frame	2	30-38	
	Shaft Set Screw, 213TC - 256TC Frame	4	30-38	
11	Backplate	1	60011+	4, 5
11F	Backplate Pin	2	60013+	
* 24	Impeller Retainer	1	60040+	
40	Deflector, 56C - 184TC Frame	1	60044+	
	Deflector, 213TC - 215TC	1	60045+	
	Deflector, 254TC - 256TC Frame	1	60046+	
71	304 SS Adapter, 56C - 145TC Frame	1	60750+	
	304 SS Adapter, 182TC - 184TC Frame	1	60751+	
	304 SS Adapter, 213TC - 215TC Frame	1	60752+	
	304 SS Adapter, 254TC - 256TC Frame	1	60753+	
71A	Adapter Pin	2	30-434	
71B	Adapter Mounting Bolt, 56C - 145TC Frame	4	30-60	
	Adapter Mounting Bolt, 182TC - 256TC Frame	4	30-36X	
75	Clamp Assembly	1	60081+	
75K	Wing Nut	1	60083+	
* 80	Inboard Rotary Seal, Carbon	1	60086+	7
80A	Cup	1	60089+	
* 80B	Seal O-Ring, Buna N	1	N70216	
	Seal O-Ring, FKM	1	V70216	
	Seal O-Ring, EPDM	1	E70216	
80C	Spring	1	60092+	
80K	Set Screw	2	30-178	
80L	Drive Collar	1	60095R1	
* 90	Casing Gasket, Buna N	1	60101+	
	Casing Gasket, FKM	1	60102+	
	Casing Gasket, EPDM	1	60627+	
131	Guard Assembly, 56C - 145TC	1	60784+	
	Guard Assembly, 182TC - 184TC Frame	1	60785+	
	Guard Assembly, 213TC - 215TC Frame	1	60786+	
	Guard Assembly, 254TC - 256TC Frame	1	60787+	
137	Water Flush Inlet Assembly, optional	1	60112+	

PL5050-CH3b

C-218 Pump Parts

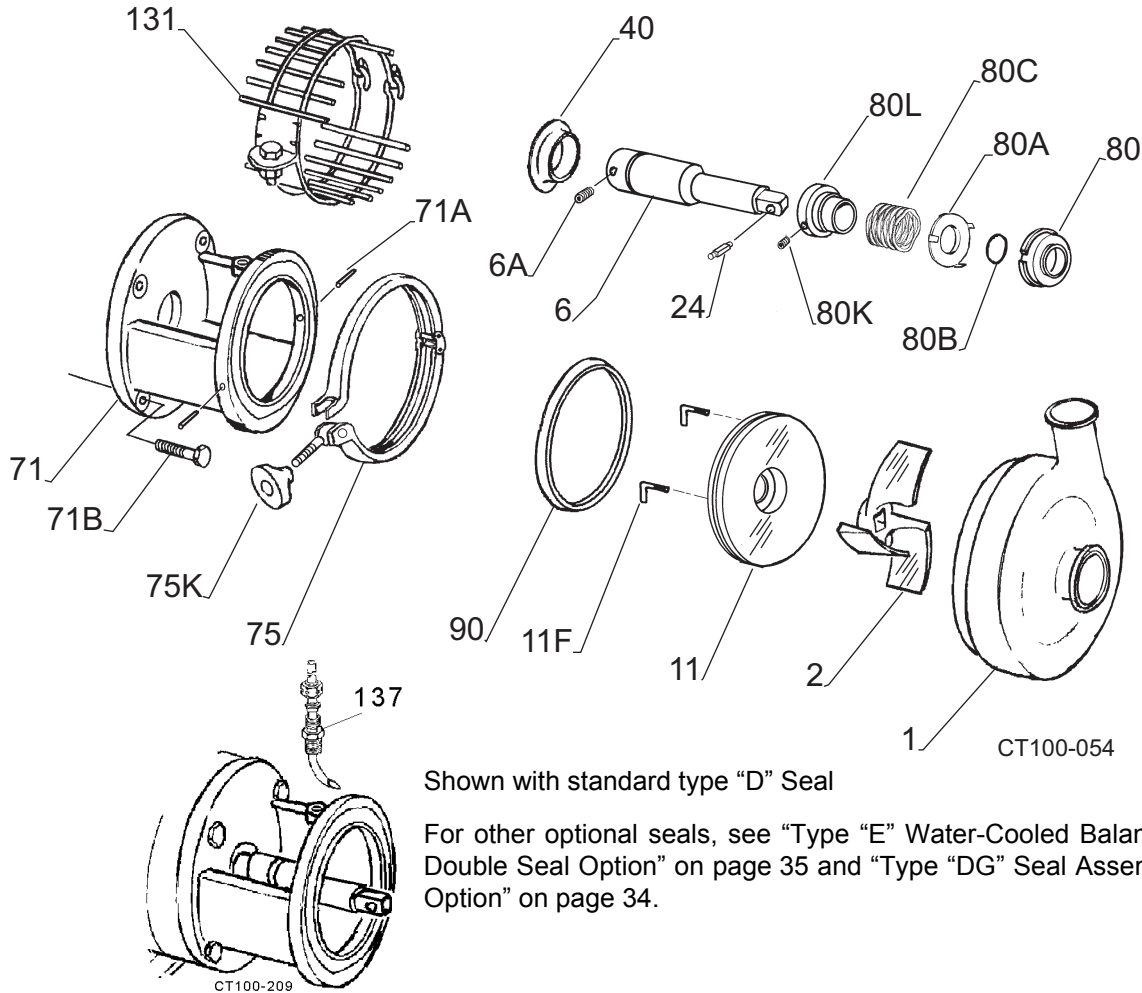

Shown with standard type "D" Seal

For other optional seals, see "Type E" Water-Cooled Balanced Double Seal Option" on page 35 and "Type DG" Seal Assembly Option" on page 34.

ITEM NO.	DESCRIPTION	QTY. PER PUMP	PART NO.	NOTES
1	Casing, 2" x 1-1/2" w/ S-Line Ports	1	60005R2	1, 4
	Casing, 3" x 1-1/2" w/ S-Line Ports	1	60006+	1, 4
2	Impeller, Full 8" Diameter	1	60029+	2, 4
6	Stub Shaft, 143TC - 145TC Frame	1	60060+	
	Stub Shaft, 182TC - 184TC Frame	1	60061+	
	Stub Shaft, 213TC - 215TC Frame	1	60062+	
	Stub Shaft, 254TC - 256TC Frame	1	60063+	
	Stub Shaft, 284TSC - 286TSC	1	60064+	
	Stub Shaft, 284TC - 286TC Frame	1	60533+	
	Stub Shaft, 324TSC - 326TSC Frame	1	60065+	
	Stub Shaft, 324TC - 326TC Frame	1	60532+	

NOTES:

PL5050-CH4

- * Recommended Spare Parts - also available in kits (see C-Series Kit Parts List page)
- 1. For casings with Bevel threaded, Female I-Line, NPT or Flanged connections, please contact factory.
- 2. Contact factory for trimmed impeller part numbers. Specify diameter required on order.
- 4. Contact factory if casing drain, passivation, or optional finish is required.
- 5. Used with standard "D" seal only.
- 7. Shown with standard type "D" Seal. See "E" and "DG" Seal pages for other seal options.

C-218 Pump Parts

ITEM NO.	DESCRIPTION	QTY. PER PUMP	PART NO.	NOTES
6A	Shaft Set Screw, 143TC - 184TC Frame	2	30-38	
	Shaft Set Screw, 213TC - 286TC Frame	4	30-38	
11	Backplate	1	60012+	4, 5
11F	Backplate Pin	2	60013+	
* 24	Impeller Retainer	1	60041+	
40	Deflector, 143TC - 184TC Frame	1	60047+	
	Deflector, 213TC - 256TC Frame	1	60046+	
	Deflector, 284TSC - 286TC Frame	1	60048+	
71	304 SS Adapter, 143TC - 145TC Frame	1	60754+	
	304 SS Adapter, 182TC - 184TC Frame	1	60755+	
	304 SS Adapter, 213TC - 215TC Frame	1	60756+	
	304 SS Adapter, 254TC - 256TC Frame	1	60757+	
	304 SS Adapter, 284TSC - 286TC Frame	1	60758+	
71A	Adapter Pin	2	30-434	
71B	Adapter Mounting Bolt, 143TC - 145TC Frame	4	30-60	
	Adapter Mounting Bolt, 182TC - 286TC Frame	4	30-36X	
75	Clamp Assembly	1	60082+	
75K	Wing Nut	1	60083+	
* 80	Inboard Rotary Seal, Carbon	1	60087+	7
80A	Cup	1	60090+	
* 80B	Seal O-Ring, Buna N	1	N70222	
	Seal O-Ring, FKM	1	V70222	
	Seal O-Ring, EPDM	1	E70222	
80C	Spring	1	60093+	
80K	Set Screw	2	30-178	
80L	Drive Collar	1	60096R1	
* 90	Casing Gasket, Buna N	1	60103+	
	Casing Gasket, FKM	1	60104+	
	Casing Gasket, EPDM	1	60628+	
131	Guard Assembly, 143TC - 145TC Frame	1	60788+	
	Guard Assembly, 182TC - 184TC Frame	1	60789+	
	Guard Assembly, 213TC - 215TC, 100/112-B5 Frame	1	60790+	
	Guard Assembly, 254TC - 256TC Frame	1	60791+	
	Guard Assembly, 284TSC - 286TC Frame	1	60792+	
137	Water Flush Inlet Assembly, optional	1	60112+	

PL5050-CH4b

C-328 Pump Parts

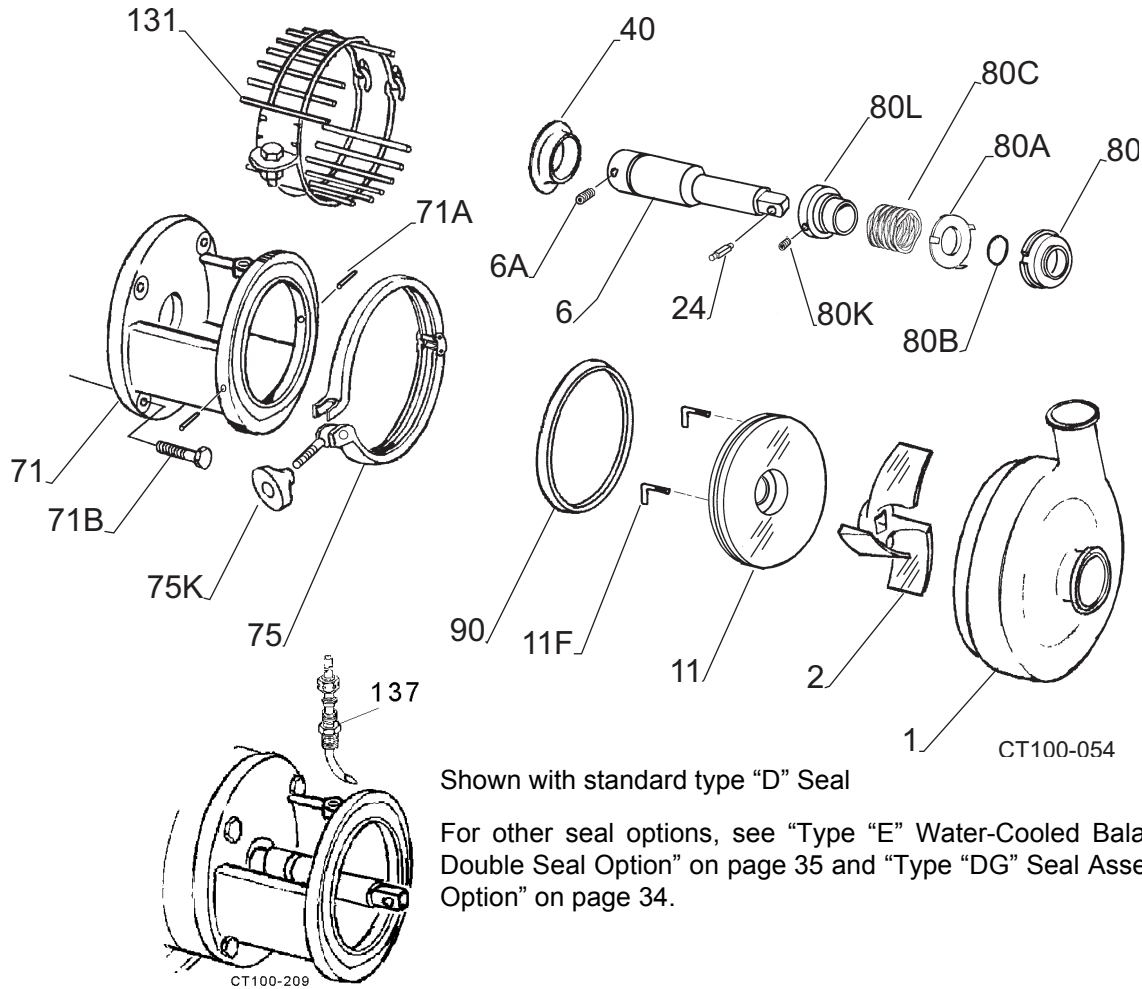

Shown with standard type "D" Seal

For other seal options, see "Type E" Water-Cooled Balanced Double Seal Option" on page 35 and "Type DG" Seal Assembly Option" on page 34.

ITEM NO.	DESCRIPTION	QTY. PER PUMP	PART NO.	NOTES
1	Casing, 3" x 2" w/ S-Line Ports	1	60007+	1, 4
	Casing, 4" x 2" w/ S-Line Ports	1	60008+	1, 4
2	Impeller, Full 8" Diameter	1	60030+	2, 4
6	Stub Shaft, 143TC - 145TC Frame	1	60060+	
	Stub Shaft, 182TC - 184TC Frame	1	60061+	
	Stub Shaft, 213TC - 215TC Frame	1	60062+	
	Stub Shaft, 254TC - 256TC Frame	1	60063+	
	Stub Shaft, 284TSC - 286TSC Frame	1	60064+	
	Stub Shaft, 284TC - 286TC Frame	1	60533+	
	Stub Shaft, 324TSC - 326TSC Frame	1	60065+	
	Stub Shaft, 324TC - 326TC Frame	1	60532+	

NOTES:

PL5050-CH5

- * Recommended Spare Parts - also available in kits (see C-Series Kit Parts List page)
- 1. For casings with Bevel threaded, Female I-Line, NPT or Flanged connections, please contact factory.
- 2. Contact factory for trimmed impeller part numbers. Specify diameter required on order.
- 4. Contact factory if casing drain, passivation, or optional finish is required.
- 5. Used with standard "D" seal only.
- 7. Shown with standard type "D" Seal. See "E" and "DG" Seal pages for other seal options.

C-328 Pump Parts

ITEM NO.	DESCRIPTION	QTY. PER PUMP	PART NO.	NOTES
6A	Shaft Set Screw, 143TC - 184TC Frame	2	30-38	
	Shaft Set Screw, 213TC - 326TC Frame	4	30-38	
11	Backplate	1	60012+	4, 5
11F	Backplate Pin	2	60013+	
* 24	Impeller Retainer	1	60041+	
40	Deflector, 182TC - 184TC Frame	1	60047+	
	Deflector, 213TC - 256TC Frame	1	60046+	
	Deflector, 284TSC - 286TC Frame	1	60048+	
	Deflector, 324TSC - 326TC Frame	1	60049+	
71	304 SS Adapter, 182TC - 184TC Frame	1	60755+	
	304 SS Adapter, 213TC - 215TC Frame	1	60756+	
	304 SS Adapter, 254TC - 256TC Frame	1	60757+	
	304 SS Adapter, 284TSC - 286TC Frame	1	60758+	
	304 SS Adapter, 324TSC - 326TC Frame	1	60759+	
71A	Adapter Pin	2	30-434	
71B	Adapter Mounting Bolt, 182TC - 286TC Frame	4	30-36X	
	Adapter Mounting Bolt, 324TC - 326TC Frame	4	30-24	
75	Clamp Assembly	1	60082+	
75K	Wing Nut	1	60083+	
* 80	Inboard Rotary Seal, Carbon	1	60087+	7
80A	Cup	1	60090+	
* 80B	Seal O-Ring, Buna N	1	N70222	
	Seal O-Ring, FKM	1	V70222	
	Seal O-Ring, EPDM	1	E70222	
80C	Spring	1	60093+	
80K	Set Screw	2	30-178	
80L	Drive Collar	1	60096R1	
* 90	Casing Gasket, Buna N	1	60103+	
	Casing Gasket, FKM	1	60104+	
	Casing Gasket, EPDM	1	60628+	
131	Guard Assembly, 182TC - 184TC Frame	1	60789+	
	Guard Assembly, 213TC - 215TC Frame	1	60790+	
	Guard Assembly, 254TC - 256TC Frame	1	60791+	
	Guard Assembly, 284TSC - 286TC Frame	1	60792+	
	Guard Assembly, 324TSC - 326TC Frame	1	60793+	
137	Water Flush Inlet Assembly, optional	1	60112+	

PL5050-CH5b

Type "DG" Seal Assembly Option

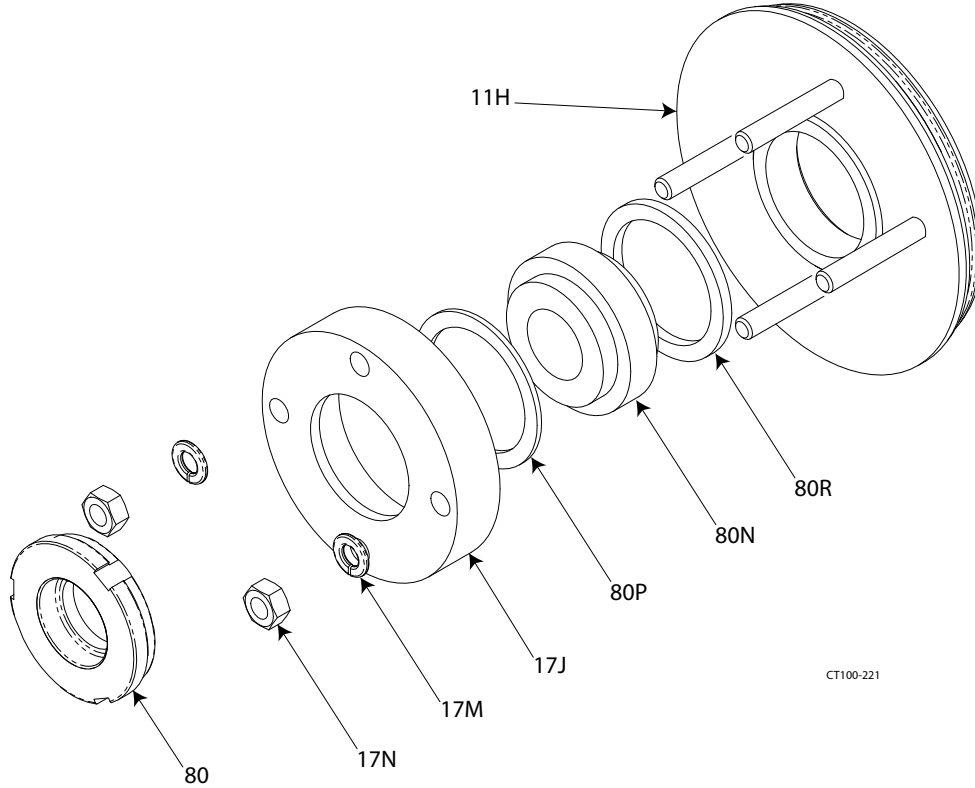

ITEM NO.	DESCRIPTION	QTY. PER PUMP	PART NO.			NOTES
			C-114	C-216	C-218 C-328	
11H	Backplate	1	60481+	60482+	60483+	4
17J	Gland Ring	1	60484+	60485+	60486+	
17K	Stud	4	60890+	60888+	60888+	
17M	Lockwasher	4	43-22	43-15	43-15	
17N	Nut	4	36-53	36-41	36-41	
* 80	Inboard Rotary Seal, Tungsten Carbide	1	113663+	113665+	113667+	
	Inboard Rotary Seal, Silicon Carbide	1	113664+	113666+	113668+	
	Inboard Rotary Seal, Carbon	1	60085+	60086+	60087+	
* 80R	PTFE Gasket - Inboard; 1/8" (3,175 mm) thick	1	60760+	60761+	60762+	
* 80N	Inboard Stationary Seal, Silicon Carbide	1	113670+	113673+	113676+	
	Inboard Stationary Seal, Ceramic	1	113671+	113674+	113677+	
	Inboard Stationary Seal, Tungsten Carbide	1	113669+	113672+	113675+	
	Inboard Stationary Seal, Siliconized Graphite	1	60374+	60375+	60376+	
* 80P	PTFE Gasket - Outboard; 1/16" (1.587 mm) thick	1	60377+	60378+	60379+	

NOTES:

PL5050-CH6

*** Recommended Spare Parts**

- 4. Contact factory if casing drain, passivation, or optional finish is required.
- 5. Carbon inboard rotary seal is supplied with standard "D" seal pump.

Type "E" Water-Cooled Balanced Double Seal Option

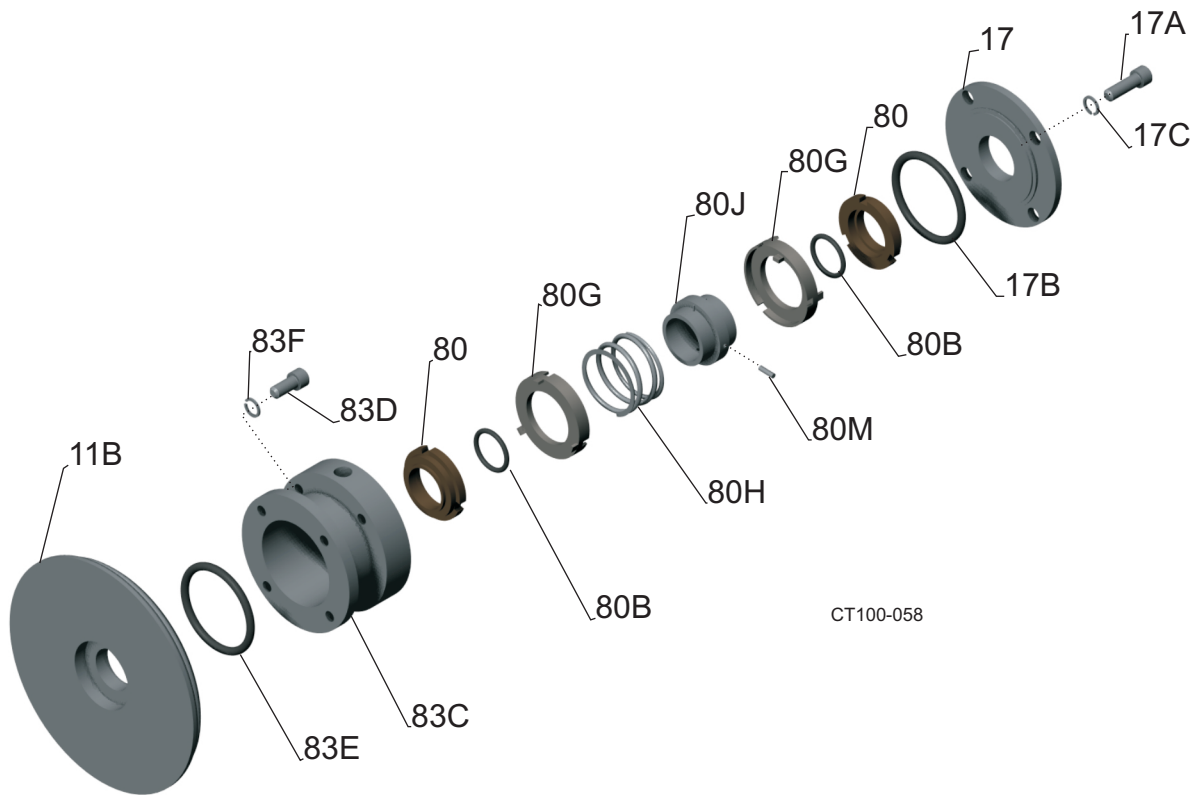

ITEM NO.	DESCRIPTION	QTY. PER PUMP	PART NO.			NOTES
			C-114	C-216	C-218 C-328	
11B	Backplate	1	60487+	60488+	60489+	4
17	Stationary Gland Ring	1	60490+	60491+	60492+	
17A	Screw	4	30-587	30-29	30-29	
* 17B	O-Ring, Buna N	1	N70033	N70034	N70038	
* 17B	O-Ring, FKM	1	V70033	V70034	V70038	
17C	Lockwasher	4	43-22	43-15	43-15	
* 80	Inboard Rotary Seal, Carbon	2	60085+	60086+	60087+	
* 80B	O-Ring, Buna N	2	N70210	N70216	N70222	
* 80B	O-Ring, FKM	2	V70210	V70216	V70222	
80G	Cup	2	60493+	60494+	60495+	
80H	Spring	1	60496+	60497+	60498+	
80J	Drive Collar	1	60499+	60500+	60501+	
80M	Set Screw	2	30-629	30-589	30-589	
83C	Stuffing Box	1	60502+	60503+	60504+	
83D	Screw	4	30-131	30-587	30-590	
* 83E	O-Ring, Buna N	1	N70034	N70037	N70153	
* 83E	O-Ring, FKM	1	V70034	V70037	V70153	
83F	Lockwasher	4	43-21	43-22	43-15	

NOTES:

PL5050-CH7

* **Recommended Spare Parts**

4. Contact factory if casing drain, passivation, or optional finish is required.

C-Series Kit Parts

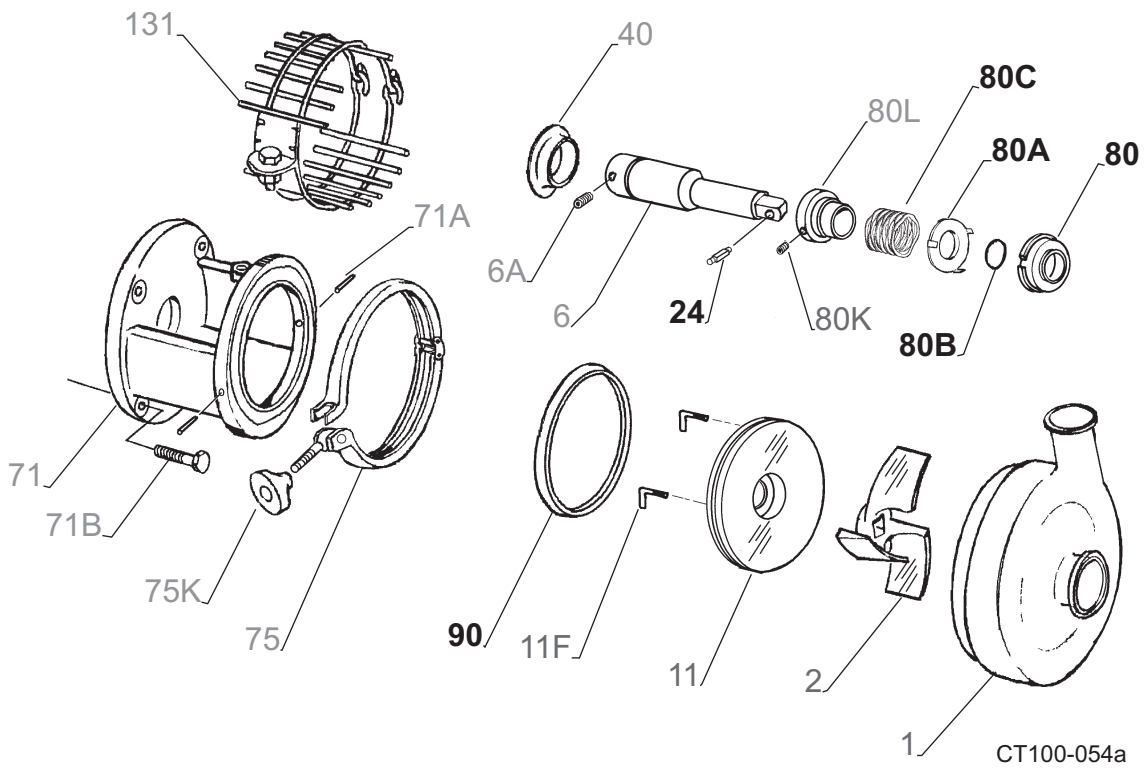

C-Series Kit Parts**C-Series Kit #1**

ITEM NO.	DESCRIPTION	QTY. REQ. PER PUMP	QTY IN KIT #1	C-100	C-114	C-216	C-218 C-328
24	Impeller Retainer	1	1	60039+	60039+	60040+	60041+
80	Seal, Carbon	1	1	60084+	60085+	60086+	60087+
80B	Seal, O-Ring, Buna N	1	1	N70214	N70210	N70216	N70222
	Seal, O-Ring, FKM			OR	V70214	V70210	V70216
90	Gasket, Casing, Buna N	1	1	N70153	60099+	60101+	60103+
	Gasket, Casing, FKM			OR	V70153	60100+	60102+
KIT #1, BUNA N				60115+	60116+	60117+	60118+
KIT #1, FKM				60119+	60120+	60121+	60122+

C-Series Kit #2

ITEM NO.	DESCRIPTION	QTY. REQ. PER PUMP	QTY IN KIT #2	C-100	C-114	C-216	C-218 C-328
80	Seal, Carbon	1	3	60084+	60085+	60086+	60087+
80B	Seal, O-Ring, Buna N	1	3	N70214	N70210	N70216	N70222
	Seal, O-Ring, FKM			OR	V70214	V70210	V70216
90	Gasket, Casing, Buna N	1	3	N70153	60099+	60101+	60103+
	Gasket, Casing, FKM			OR	V70153	60100+	60102+
KIT #2, BUNA N				60262+	60263+	60264+	60265+
KIT #2, FKM				60266+	60267+	60268+	60269+

C-Series Kit #3

ITEM NO.	DESCRIPTION	QTY. REQ. PER PUMP	QTY. IN KIT #3	C-100	C-114	C-216	C-218 C-328
80	Seal, Carbon	1	1	60084+	60085+	60086+	60087+
80A	Cup	1	1	60088+	60088+	60089+	60090+
80B	Seal, O-Ring, Buna N	1	1	N70214	N70210	N70216	N70222
	Seal, O-Ring, FKM			OR	V70214	V70210	V70216
80C	Spring	1	1	60091+	60091+	60092+	60093+
KIT #3, BUNA N				60123+	60124+	60125+	60126+
KIT #3, FKM				60127+	60128+	60129+	60130+

PL5050-CH8

Motor Mounts - NEMA Frame Sizes

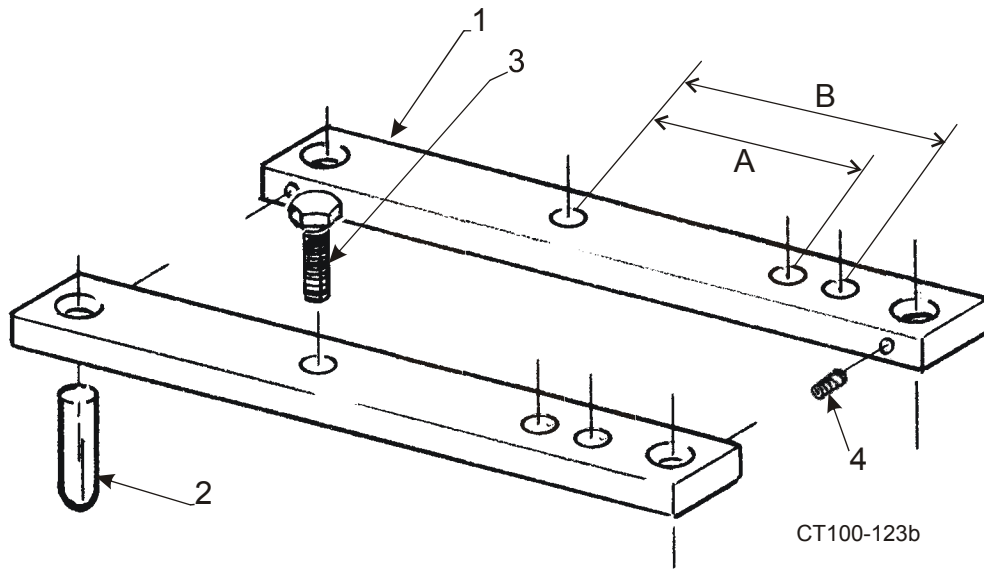

NEMA FRAME SIZE	COMPLETE MOUNTING KIT	ITEM 1 (BAR) PART NO.	ITEM 2 (LEG) PART NO.	ITEM 3 (HHCS) PART NO.	ITEM 4 (SHSS) PART NO.	"A" DIMENSION (in.)	"B" DIMENSION (in.)
56C	114365+	114364+	110264+	30-151	30-625	3.0	--
143/145	110256+	110262+	110264+	30-151	30-625	4.0	5.0
182/184	110255+	110261+	110264+	30-30	30-625	4.5	5.5
213/215	110254+	110260+	110264+	30-30	30-625	5.5	7.0
254/256	110253+	110259+	110263+	30-36X	30-626	8.25	10.0
284/286	110252+	110258+	110263+	30-36X	30-626	9.5	11.0
324/326	110251+	110257+	110263+	30-24	30-626	10.5	12.0
364	110251A	110257+	110263+	30-24	30-626	11.25	--

PL5050-CH14

Troubleshooting

Problem	Possible Cause	Suggested Action
Not Enough Liquid Delivered	Pump not primed.	Prime pump. Install a priming system if possible.
	Suction or discharge plugged or closed.	Open suction. If plugged, shut down the pump and remove blockage.
	Air leak in supply or at seal area.	Check system for air leaks and repair as necessary. Replace seals if required.
	Wrong direction of rotation.	Adjust motor electrical wiring to correct rotation.
	Discharge head too high.	Lower discharge head until pump can move material without turning to freely causing overload.
	Suction lift too high.	Lower pump in system until the pump is easily supplied with material.
	Speed too slow (low voltage, wrong frequency, wrong motor).	Adjust voltage and frequency. Change motor if necessary.
	Excessive air in material.	Adjust system to remove excess air from material before it reaches the pump.
Not Enough Pressure	Insufficient NPSH (Net Positive Suction Head) available.	Adjust system to provide correct NPSH.
	Impeller diameter too small for duty.	Contact your SPX Customer Service Representative for sizing information. SPX Customer Service Telephone: 1-800-252-5200 or 262-728-1900
	Air leak in supply or at seal area.	Check system for air leaks and repair as necessary. Replace seals if required.
	Wrong direction of rotation.	Adjust motor electrical wiring to correct rotation.
	Speed too slow (low voltage, wrong frequency, wrong motor).	Adjust voltage and frequency. Change motor if necessary.
Motor Overload	Excessive air in material.	Adjust system to remove excess air from material before it reaches the pump.
	Impeller diameter too small for duty.	Contact your SPX Customer Service Representative for sizing information. SPX Customer Service Telephone: 1-800-252-5200 or 262-728-1900
Motor Overload	Faulty electrical connections.	Check wiring and repair/replace as necessary.
	Unrestricted discharge resulting in too high a flow rate.	Add discharge restriction to lower flow rate.

Problem	Possible Cause	Suggested Action
	Impeller interference.	Disassemble pump and inspect for damage. Remove interference if still present. Replace worn/damaged parts.
	Seal binding.	Disassemble pump and inspect for damage. Check for material crystallization on seals.
	Discharge head too low allowing pump to deliver too much liquid.	Raise discharge head until pump achieves proper resistance to flow.
	Liquid heavier or more viscous than rating.	Contact your SPX Customer Service Representative for sizing information.
	Overload heaters too small for motor.	Inspect and replace as necessary.
	Electrical supply, voltage, frequency, incorrect.	Adjust voltage and frequency. Change motor if necessary.
	Impeller diameter too large for duty.	Contact your SPX Customer Service Representative for sizing information. SPX Customer Service Telephone: 1-800-252-5200 or 262-728-1900
	Defective motor.	Replace motor.
Vibration/Noise	Pump not level.	Make sure all legs are touching the floor. Level pump.
	Piping not supported.	Support all piping as described in the installation section.
	Starved suction/Supply line blocked.	Shut down pump and remove blockage.
	Foreign material in pump.	Disassemble pump, remove all foreign material and inspect for damage. Replace worn/damaged parts.
	Starved suction/Insufficient NPSH (Net Positive Suction Head) available.	Adjust system to provide correct NPSH.
	Impeller hub/impeller shaft worn.	Disassemble pump and inspect for damage. Replace worn parts.
	Impeller shaft loose or bent.	Disassemble pump and inspect for damage.
	Impeller out of balance.	Disassemble pump and inspect for damage. Replace impeller.
	Motor bearings worn.	Disassemble motor and inspect for damage. Replace worn parts.
	Starved suction/Supply line too long.	Shorten system supply line.

Problem	Possible Cause	Suggested Action
	Starved suction/Supply line too small.	Install larger supply lines.
	Excessive air in material.	Adjust system to remove excess air from material before it reaches the pump.
Rapid Seal Wear	Incorrect impeller shaft location; excessive spring loading.	Adjust pump alignment to motor and piping.
	Water Hammer.	Adjust system to reduce air in system and sudden starts or stops in flow.
	Impeller shaft loose or bent.	Disassemble pump and inspect for damage. Replace worn/damaged parts.
	Abrasive product.	Contact your SPX Customer Service Representative for alternate seal information. SPX Customer Service Telephone: 1-800-252-5200 or 262-728-1900
	Prolonged "dry" running.	Adjust process to insure pump has a continual fresh supply of product during operation.
	Abrasive solids (unfiltered) in flush water supplied to seal.	Use only filtered water in seal flush system.
Seal Leaks	Gasket damaged or worn.	Disassemble pump and inspect for damage.
	Seal not installed correctly.	Disassemble pump and inspect seal for damage (replace if necessary). Install seal correctly and assemble pump.
	Carbon seal worn or damaged.	Disassemble pump and inspect seal for damage (replace if necessary).
	Inlet/Outlet connection loose or no gasket.	Inspect inlet/outlet connection for gasket and tighten connection.
	Casing clamp loose.	Tighten clamp.

Notes

C-Series

CENTRIFUGAL PUMP - NEMA VERSION



SPX FLOW TECHNOLOGY

611 Sugar Creek Road

Delavan, WI 53115

P: (262) 728-1900 or (800) 252-5200

F: (262) 728-4904 or (800) 252-5012

E: wcb@spx.com

SPX reserves the right to incorporate our latest design and material changes without notice or obligation.

Design features, materials of construction and dimensional data, as described in this bulletin, are provided for your information only and should not be relied upon unless confirmed in writing.

Please contact your local sales representative for product availability in your region. For more information visit www.spx.com.

The green ">" is a trademark of SPX Corporation, Inc.

ISSUED: 10/2012

COPYRIGHT © 2012 SPX Corporation